

MITSUBISHI

A/D converter unit for A0J2 type A0J2-68AD

User's Manual

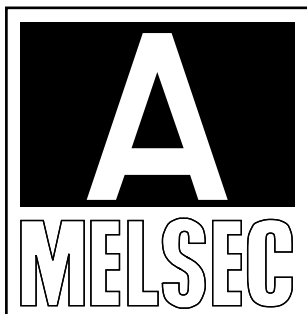
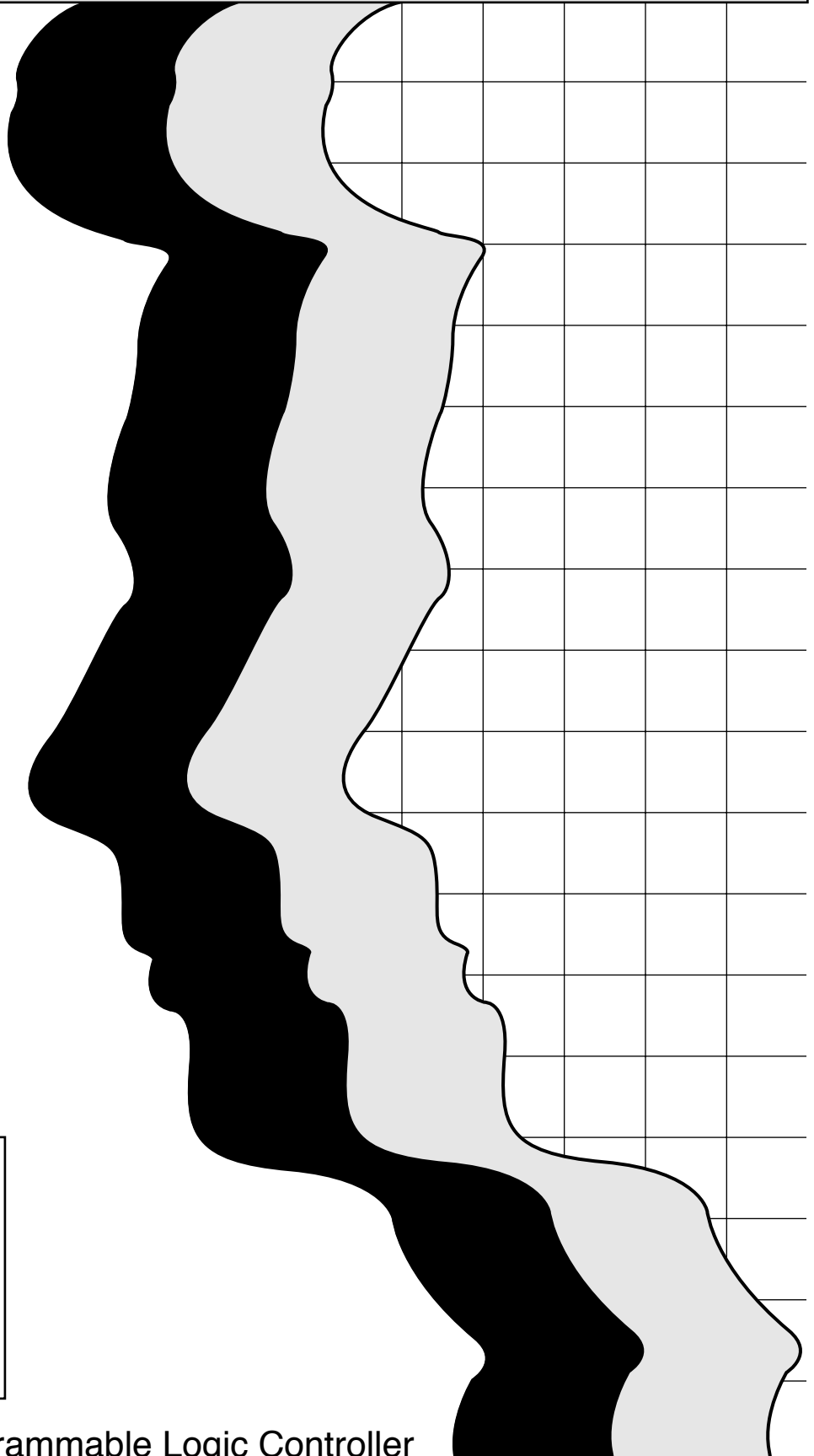

Mitsubishi Programmable Logic Controller

● SAFETY PRECAUTIONS ●

(Read these precautions before using.)

When using Mitsubishi equipment, thoroughly read this manual and the associated manuals introduced in this manual. Also pay careful attention to safety and handle the module properly.

These precautions apply only to Mitsubishi equipment. Refer to the CPU module user's manual for a description of the PC system safety precautions.

These ● SAFETY PRECAUTIONS ● classify the safety precautions into two categories: "DANGER" and "CAUTION".



DANGER

Procedures which may lead to a dangerous condition and cause death or serious injury if not carried out properly.



CAUTION

Procedures which may lead to a dangerous condition and cause superficial to medium injury, or physical damage only, if not carried out properly.

Depending on circumstances, procedures indicated by  CAUTION may also be linked to serious results.

In many case, it is important to follow the directions for usage.

Store this manual in a safe place so that you can take it out and read it whenever necessary.
Always forward it to the end user.

[Cautions on Design]

CAUTION

- Do not bundle the control wire and the communication cable with the main circuit or power line or keep them close to one another.
Keep the control wire and the communication cable at least 100 mm (3.94 inch) away from the main circuit or power line: otherwise, noise or malfunctions will occur.

[Cautions on Installation]

CAUTION

- Use the PLC in the environment specified in the General Specifications section in this manual. Using it in an environment which does not meet the general specifications could cause electric shock, fire or malfunctions, and damage or deterioration of the module.
- Connect the I/O cable and extension cable securely with the catch on the unit's connector. If the cable is not connected securely, malfunctions may occur due to faulty contact.
- Mount the unit to the panel securely, with screws, for example. A unit that is not fixed securely could fall, or cause malfunction, trouble.
- Tighten the screw in the specified torque range. Undertightening can cause a drop, short circuit or malfunction. Overtightening can cause a drop, short circuit or malfunction due to damage to the screw or unit.

[Cautions on Wiring]

CAUTION

- Ground the ANALOG GND terminal and FG terminal with grounding dedicated for the PLC, especially when there are high levels of noise. Failure to observe this could lead to erroneous operation. If you do not, the PC will malfunction.
- Before connecting wires to the PLC, check the rated voltage and the terminal arrangement. Connecting power of a different voltage or wiring incorrectly will result in fire or failure.
- Tighten the terminal screws to the specified torque. Loose terminal screws will cause a short, fire or malfunctions. Overtightening can cause a drop, short circuit or malfunction due to damage to the screw or unit.
- Take all possible measures to prevent chips or wire scraps from entering the module. Entry of foreign material will cause fire, failure of malfunctions.

[Cautions on Start-Up and Maintenance]

 **DANGER**

- Do not touch the terminals while they are live. This will cause malfunctions.
- Switch all phases of the external power supply off when cleaning the module or tightening the terminal screws.
Not doing so can cause a module failure or malfunction.
Undertightening can cause a drop, short circuit or malfunction. Overtightening can cause a drop, short circuit or malfunction due to damage to the screw or module.
- Always make sure to touch the grounded metal to discharge the electricity charged in the body, etc., before touching the module.
Failure to do may cause a failure or malfunctions of the module.

 **CAUTION**

- Do not disassemble or tamper with the module.
This will cause failure, malfunctions, injuries or fire.
- Switch all phases of the external power supply off when installing or removing the I/O cables and extension cables.
If the power is left on, the module will break down or malfunction.
- If a voltage is input when a current input range is selected, failure may occur.

[Cautions on Disposal]

 **CAUTION**

- Dispose of the module as industrial waste.

REVISIONS

※The manual number is given on the bottom left of the back cover.

Print Date	*Manual Number	Revision
Nov., 1986	IB (NA) 66098-A	First edition
May., 1987	IB (NA) 66098-B	Correction Page 6-4
Dec., 1988	IB (NA) 66098-C	Correction Page 2-1, 6-3, 6-7 "Instructions for Strategic Materials" added
Jul., 1997	IB (NA) 66098-D	Correction Section 2.2.3, 4.2, 6.1, 6.2.1, 6.2.3, 6.2.6 Addition SAFETY PRECAUTIONS Section 2.2.2
May, 2000	IB (NA) 66098-E	Addition WARRANTY Part Addition Section 2.2.2 Correction SAFETY PRECAUTIONS, Section 2.1, 2.2.1, 3.1
July, 2003	IB (NA) 66098-F	Correction SAFETY PRECAUTIONS, Chapter1, Section 4.2

Japanese Manual Version IB-68011-F

This manual confers no industrial property rights or any rights of any other kind, nor does it confer any patent licenses. Mitsubishi Electric Corporation cannot be held responsible for any problems involving industrial property rights which may occur as a result of using the contents noted in this manual.

INTRODUCTION

Thank you for choosing the Mitsubishi MELSEC-A Series of General Purpose Programmable Controllers. Please read this manual carefully so that the equipment is used to its optimum. A copy of this manual should be forwarded to the end User.

CONTENTS

1. GENERAL DESCRIPTION	1-1 ~ 1-1
2. SPECIFICATIONS	2-1 ~ 2-13
2.1 General Specifications	2-1
2.2 Performance Specifications	2-2
2.2.1 Specifications	2-2
2.2.2 I/O conversion characteristics	2-3
2.2.3 Digital output system	2-7
2.3 I/O List with Respect to Programmable Controller CPU	2-9
2.4 Buffer Memory	2-10
2.4.1 Assignment of buffer memory	2-10
2.4.2 Contents and data configuration of buffer memory	2-11
3. HANDLING	3-1 ~ 3-5
3.1 Handling Instructions	3-1
3.2 Nomenclature	3-2
3.2.1 Nomenclature	3-2
3.2.2 Unit number setting	3-3
3.2.3 Internal power supply (5 VDC) setting	3-4
3.2.4 Internal power supply (5 VDC) checking	3-5
4. WIRING	4-1
4.1 Wiring Instructions	4-1
4.2 Unit Connection Example	4-1
5. CONCEPT OF THE 68AD I/O NUMBERS IN A0J2 SYSTEM	5-1 ~ 5-2
5.1 I/O Number Assignment and Concept	5-1
5.2 Concept of Parallel I/O Assignment for Use with Remote Station	5-2
6. PROGRAMMING	6-1 ~ 6-6
6.1 Initial Setting	6-1
6.2 Programs	6-2
6.2.1 Basic programs for read and write	6-2
6.2.2 Setting of the number of channels	6-3
6.2.3 Setting of averaging time or averaging count	6-3
6.2.4 Averaging processing specification	6-3
6.2.5 Read of digital output value	6-4
6.2.6 Read and reset of write data error code	6-4
6.2.7 Application circuit examples	6-5

7. TEST OPERATION AND CALIBRATION	7-1 ~ 7-3
7.1 Offset/Gain Setting	7-1
7.2 Checks before Starting	7-3
8. TROUBLESHOOTING	8-1 ~ 8-7
8.1 Write Data Error Code List	8-1
8.2 Troubleshooting	8-2
8.2.1 Troubleshooting flow chart	8-2
8.2.2 Flow chart used when "RUN" LED has flickered	8-3
8.2.3 Flow chart used when "RUN" LED has turned off	8-4
8.2.4 Flow chart used when digital output value cannot be read	8-5
8.2.5 Flow chart used when data, such as the number of channels, cannot be written	8-6
APPENDIX	APP-1
APPENDIX 1 EXTERNAL DIMENSIONS	APP-1

1. GENERAL DESCRIPTION

This User's Manual describes the specifications, handling, programming procedures, etc. of the A0J2-68AD analog-digital converter unit (hereinafter referred to as "68AD") which is used in combination with the A0J2CPU/A0J2HCPU unit.

The general description of each chapter is as follows:

Chapter 2 Specifications

Describes the specifications and functions.

Chapter 3 Handling

Describes the handling instructions, nomenclature, and settings.

Chapter 4 Wiring

Describes the wiring.

Chapter 5 Concept of the 68AD I/O Numbers in A0J2 System

Gives the 68AD I/O number concept and precautions.

Chapter 6 Programming

Gives the programming procedures and application circuits.

Chapter 7 Test Operation and Adjustments

Describes offset/gain setting and items to be checked before test operation is initiated.

Chapter 8 Troubleshooting

Describes problems in programs and hardware.

Appendix

External dimensions.

POINT

In this manual, the I/O assignment numbers of the 68AD assume that the unit number is set to 0. If the unit number is set to other than 0, determine the 68AD assignment number according to the I/O assignment procedure in the Programming Manual.

2. SPECIFICATIONS

2. SPECIFICATIONS

This chapter describes the general specifications and performance specifications of the 68AD.

2.1 General Specifications

The general specifications of 68AD are indicated in Table 2.1.

Item	Specifications				
Operating ambient temperature	0 to 55°C				
Storage ambient temperature	-20 to 75°C				
Operating ambient humidity	10 to 90%RH, no condensation				
Storage ambient humidity	10 to 90%RH, no condensation				
Vibration resistance	Conforms to JIS C 0911	Frequency	Accélération	Amplitude	Sweep Count
		10 to 55Hz	—	0.075mm (0.003 inch)	10 times * (1 octave/minute)
		55 to 150Hz	9.8 m/s ²	—	
Shock resistance	Conforms to JIS C 0912 (9.8 m/s ² x 3 times in 3 directions)				
Noise durability	By noise simulator 1500Vpp noise voltage, 1μs noise width and 25 to 60Hz noise frequency				
Dielectric withstand voltage	500 VAC for 1 minute across batch of DC external terminals and ground				
Insulation resistance	5MΩ or larger by 500 VDC insulation resistance tester across batch of DC external terminals and ground				
Operating ambience	To be free from corrosive gases. Dust should be minimal.				
Cooling method	Self-cooling				

Table 2.1 General Specifications

REMARKS

One octave marked * indicates a change from the initial frequency to double or half frequency. For example, any of the changes from 10Hz to 20Hz, from 20Hz to 40Hz, from 40Hz to 20Hz, and 20Hz to 10Hz are referred to as one octave.

2. SPECIFICATIONS



2.2 Performance Specifications

2.2.1 Specifications

Table 2.2 Performance Specifications

Item	Specifications												
Analog input	Selection depends on input terminals. Voltage: -10 to 0 to +10V DC (Input resistance: 30k Ω) Current: + 4 to +20mA DC (Input resistance: 250 Ω) -20 to 0 to +20mA can also be used for current input.												
Digital output	A CPU: 16-bit, signed binary (-2048 to +2047)												
I/O characteristics	<table border="1"> <thead> <tr> <th>Analog Input</th> <th>Digital Output</th> </tr> </thead> <tbody> <tr> <td>+10V</td> <td>+2000</td> </tr> <tr> <td>+5V or +20mA</td> <td>+1000</td> </tr> <tr> <td>0V or +4mA</td> <td>± 0</td> </tr> <tr> <td>-5V or -12mA</td> <td>-1000</td> </tr> <tr> <td>-10V</td> <td>-2000</td> </tr> </tbody> </table>	Analog Input	Digital Output	+10V	+2000	+5V or +20mA	+1000	0V or +4mA	± 0	-5V or -12mA	-1000	-10V	-2000
	Analog Input	Digital Output											
	+10V	+2000											
	+5V or +20mA	+1000											
	0V or +4mA	± 0											
	-5V or -12mA	-1000											
-10V	-2000												
Refer to section 2.2.2 for details.													
Maximum resolution	Voltage: 5mV (1/2000) Current: 20 μ A (1/1000)												
Overall accuracy*	$\pm 1\%$ (± 20)												
Maximum conversion speed	Maximum 2.5 μ s/channel												
Absolute maximum input	Voltage: ± 15 V Current: ± 30 mA												
Number of analog input points	8 channels/unit												
Insulation method	Photocoupler insulation between output terminals and PC power (Non-insulated between channels)												
Number of I/O points	Special 64 points												
Connection terminal	36-point terminal block												
Applicable wire size	0.75 to 2mm ² (Applicable tightening torque: 39 to 59N-cm)												
Applicable solderless terminal	V1.25-3, V1.25-YS3A, V2-S3, V2-YS3A												
Internal current consumption (5V DC)	0.7A												
Weight kg (lb)	0.675 (1.49)												

* This is the accuracy in respect to the maximum digital output value (+2000).
The same value (+2000) applies for the current input and voltage input.

POINT

Analog input allowed for maximum resolution and overall accuracy, is from -10 to 0 to +10V or from -20 to 0 to +20mA.

2.2.2 I/O conversion characteristics

I/O conversion characteristics are dictated by the offset value and gain value set in test mode. Fig. 2.1 shows an example for voltage input.

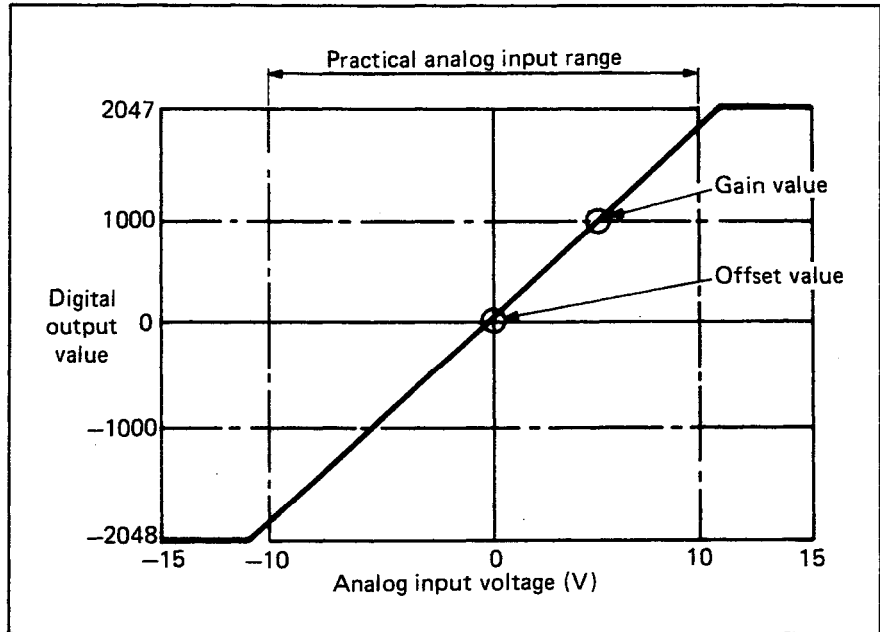

Fig. 2.1 I/O Conversion Characteristics

REMARKS

1. The offset value is the analog input (voltage or current) value at which the digital output value is 0. Set the offset value in test mode.
2. The gain value is the analog input (voltage or current) value at which the digital output value is 1000. Set the gain value in test mode.

POINT

When setting the offset and gain values, the following conditions must be satisfied. If not satisfied, proper conversion characteristics of this unit are not guaranteed.

For voltage output: Gain value – offset value $\geq 1V$
 For current output: Gain value – offset value $\geq 4mA$

(1) Voltage input characteristic

Fig. 2.2 shows the voltage characteristics for three different offset/gain combinations.

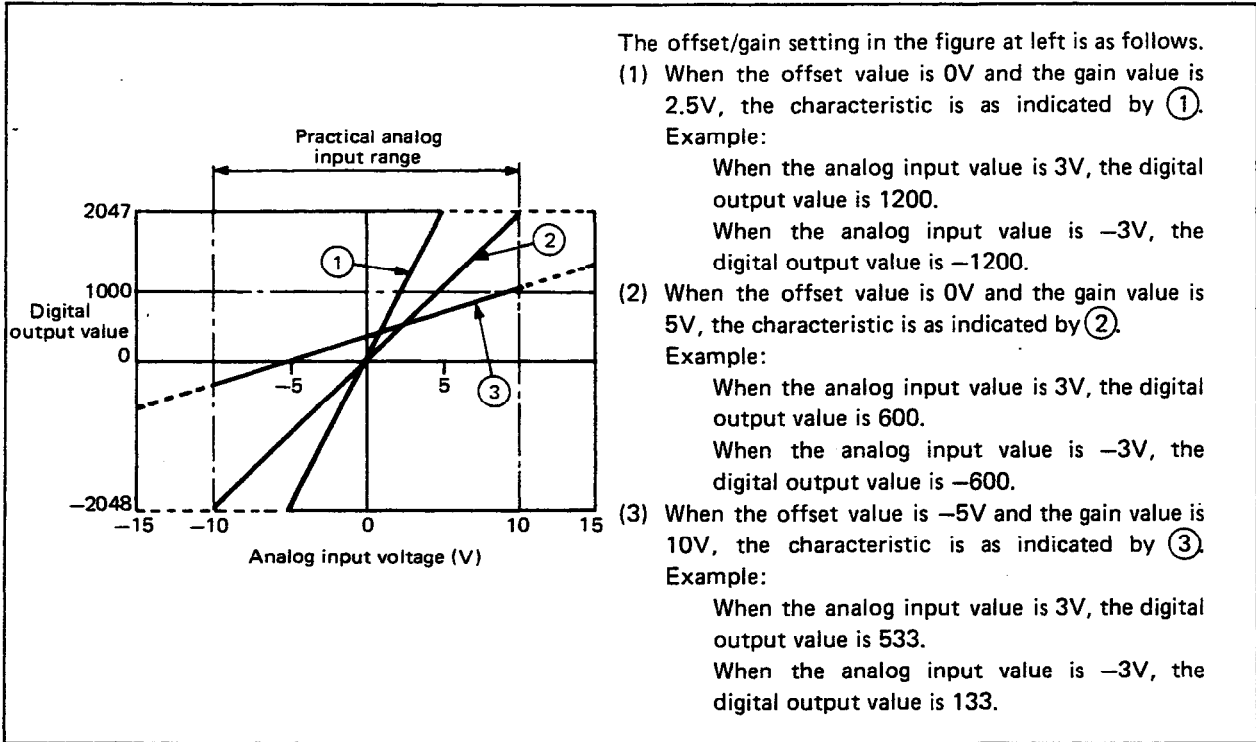

The offset/gain setting in the figure at left is as follows.

- (1) When the offset value is 0V and the gain value is 2.5V, the characteristic is as indicated by ①.

Example:

When the analog input value is 3V, the digital output value is 1200.

When the analog input value is -3V, the digital output value is -1200.

- (2) When the offset value is 0V and the gain value is 5V, the characteristic is as indicated by ②.

Example:

When the analog input value is 3V, the digital output value is 600.

When the analog input value is -3V, the digital output value is -600.

- (3) When the offset value is -5V and the gain value is 10V, the characteristic is as indicated by ③.

Example:

When the analog input value is 3V, the digital output value is 533.

When the analog input value is -3V, the digital output value is 133.

Fig. 2.2 Voltage Input Characteristic

POINTS

1. When the input voltage is in the range from -10 to 0 to +10V, the maximum resolution and overall accuracy are within the quoted range of performance specifications. However, if this range is exceeded, resolution and accuracy will be impaired. (Avoid use within the regions indicated by dotted lines in Fig. 2.2 since the accuracy in these regions is not within that stated in the performance specifications.)
2. If an analog input corresponding to a digital output value of more than +2047 or less than -2048 is applied, the digital output value will not exceed +2047 or -2048.
3. Do not apply $\pm 15V$ or more. This will damage the unit.
4. In offset/gain setting, the offset value should always be less than the gain value. If the offset value is greater than or equal to the gain value, the digital output value will be unpredictable.

(2) Current input characteristic

Fig. 2.3 shows the current characteristics for two different offset/gain combinations.

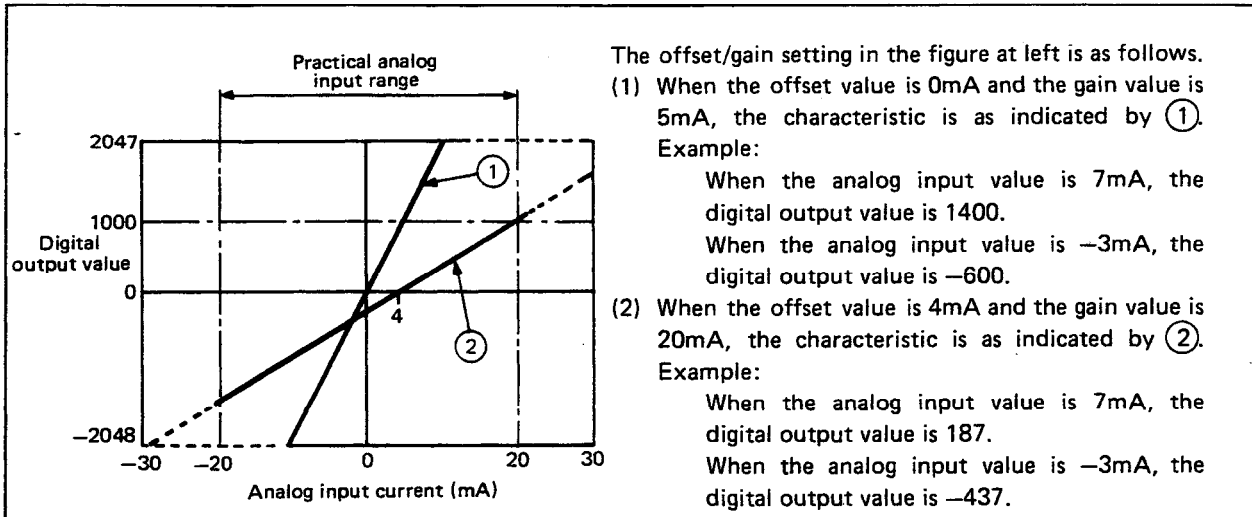

Fig. 2.3 Current Input Characteristic

POINTS

1. When the input current is in the range from -20 to 0 to +20mA, the maximum resolution and overall accuracy are within the quoted range of performance specifications. However, if this range is exceeded, resolution and accuracy will be impaired.
2. If an analog input, corresponding to a digital output value of more than +2047 or less than -2048 is applied, the digital output value will not exceed +2047 or -2048.
3. Do not apply ±30mA or more. This will damage the unit.
4. In offset/gain setting, the offset value should always be less than the gain value. If the offset value is greater than or equal to the gain value, the digital output value will be unpredictable.

(3) Relation between offset/gain setting and digital output value

The maximum resolution of the 68AD is 5mV in voltage and 20µA in current. Maximum resolution may be found using the following expression:

$$\frac{(\text{Gain value}) - (\text{offset value})}{1000} < (\text{maximum resolution})$$

Fig. 2.4 and 2.5 show the relation between the offset/gain setting and the digital output value for the offset/gain settings in Fig. 2.2 and 2.3.

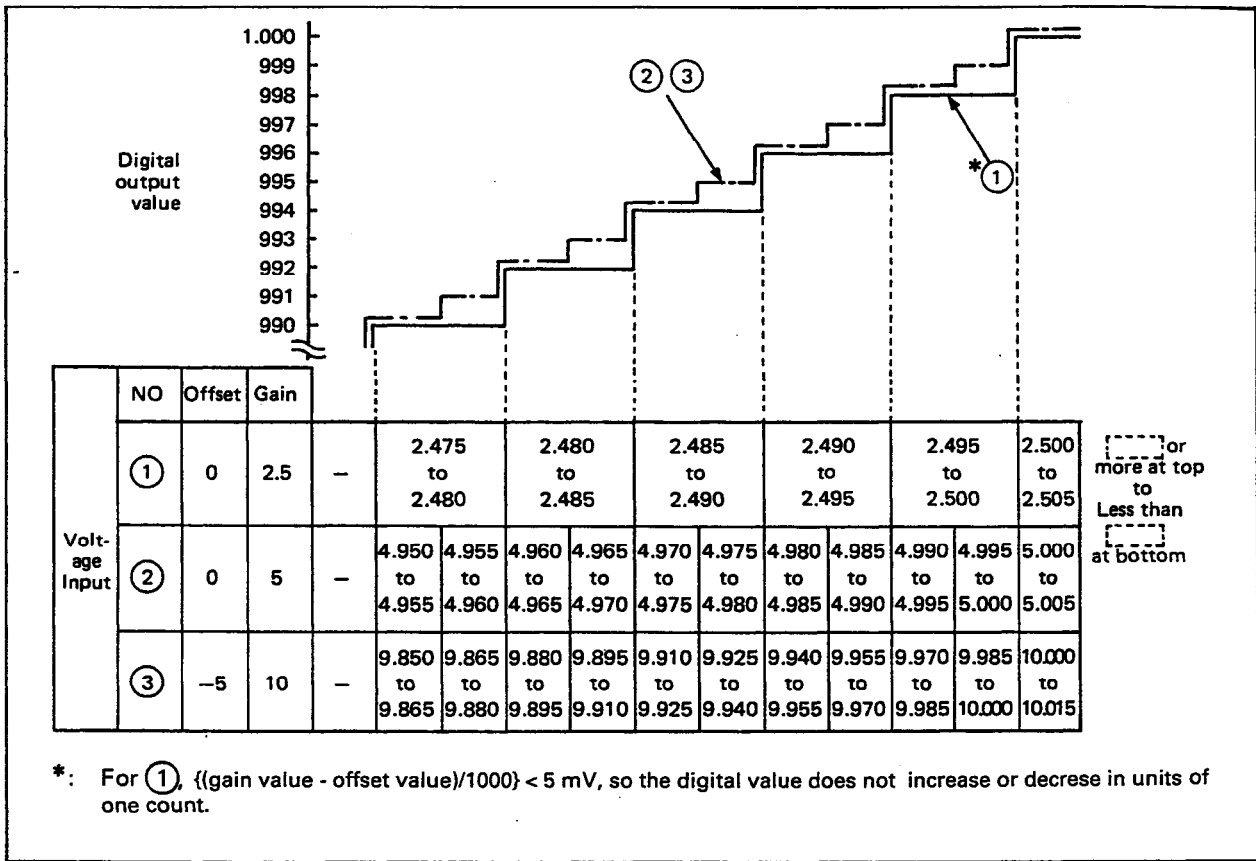

Fig. 2.4 Voltage Input and Digital Output Value

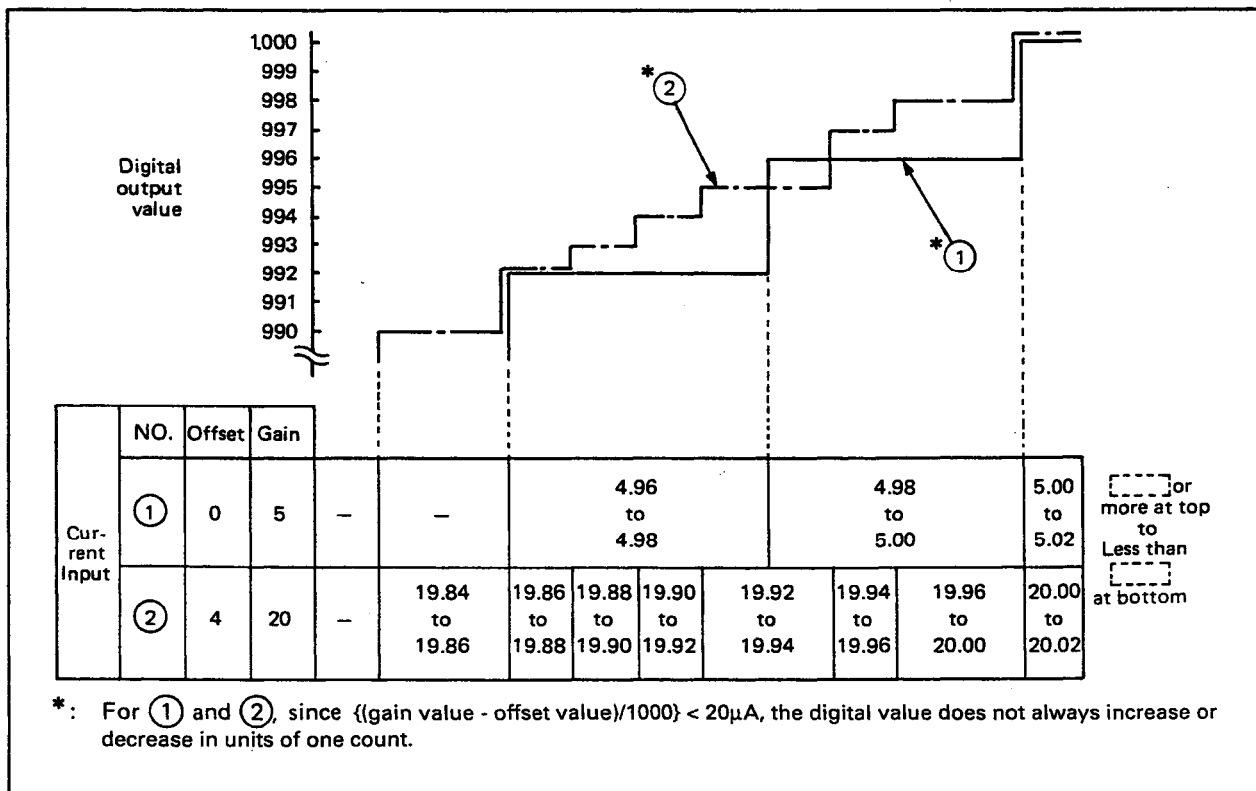

Fig. 2.5 Current Input and Digital Output Value

(4) Overall accuracy

The overall accuracy is the accuracy in respect to the maximum digital output value.

Even if the input characteristics are changed by changing the offset/gain settings, the overall accuracy will not change and will be kept within the range of the performance specifications. The overall accuracies of the power/current output characteristics are shown in Fig. 2.6 and Fig. 2.7.

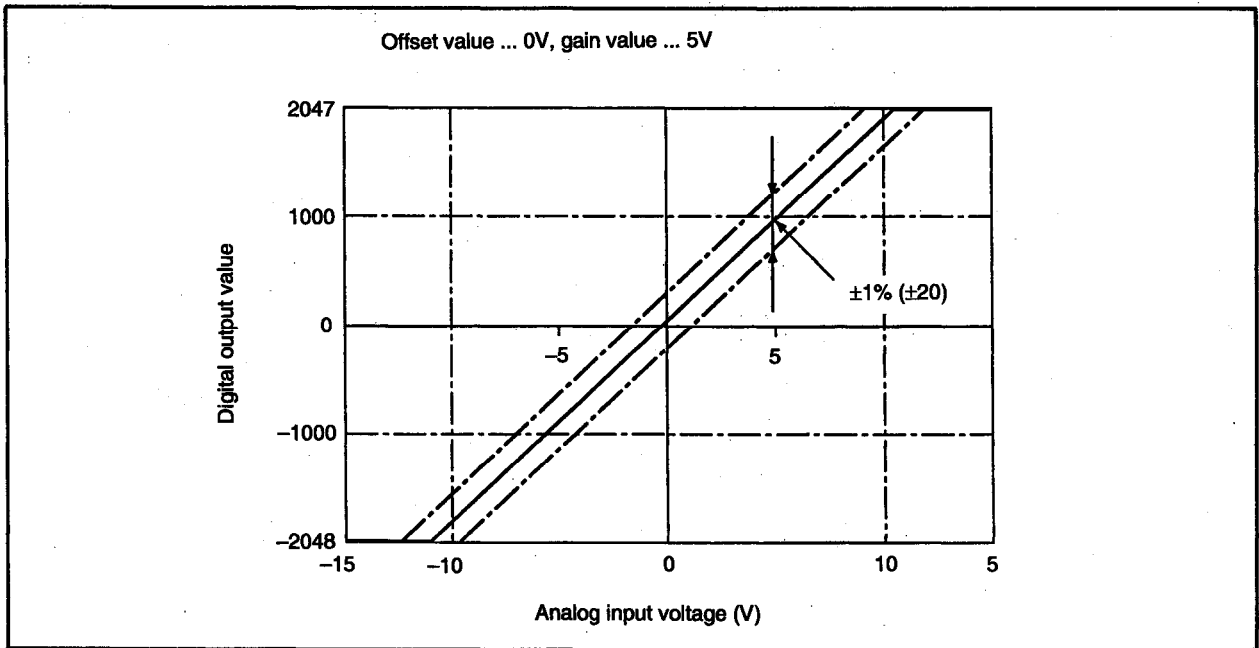

Fig. 2.6 Overall accuracy of voltage input characteristics

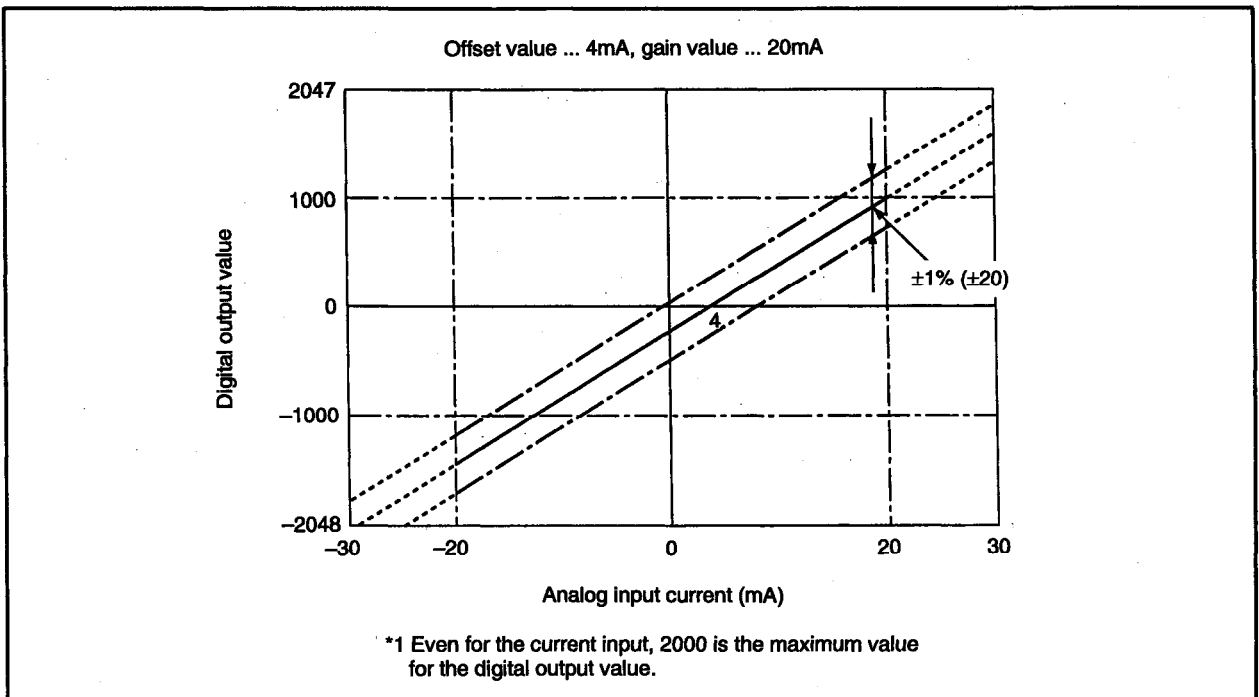

Fig. 2.7 Overall accuracy of current input characteristics

2.2.3 Digital output system

The digital output value of the 68AD is determined by the following:

(1) I/O conversion characteristics:

- Offset value
- Gain value

The digital output value depends on the offset value and gain value which have been set in test mode.

(2) A/D conversion system:

- Sampling processing
- Averaging processing
 - Averaging processing in terms of count. 1 to 4000 times
 - Averaging processing in terms of time. 20 to 10000ms

1) Sampling processing

The analog input values are converted to digital output values one by one and the digital output values are stored in the buffer memory.

2) Averaging processing

The 68AD makes the A/D conversion for any channels to which averaging processing has been specified from the programmable controller CPU. Using a preset count or a preset period of time, an average is calculated (excluding the maximum value and the minimum value,) and stored to the buffer memory. If the processing count is specified as two or less, sampling processing is applied.

POINTS

(1) Sampling Processing

The time taken for the sampled digital output values to be stored in the buffer memory varies depending on the number of channels used.

$$(\text{Processing time}) = (\text{number of channels used}) \times 2.5(\text{ms/channel})$$

↑
Max. conversion speed

Example: When the number of channels used is 5.

$$5 \times 2.5 = 12.5(\text{ms})$$

(2) Averaging Processing by Specifying Time

(1) The set time can be set in units of 10 ms, and any remainder of less than 10 ms is discarded.

Example: If 1234 ms is set, it is treated as 1230 ms.

(2) The number of samples taken in the set time depends on the number of A/D conversion channels.

$$(\text{Processing count}) = \frac{\text{Set time}}{(\text{Number of channels used}) \times 2.5(\text{ms/channel})}$$

↑
Max. conversion speed

Example: When the number of channels used is 4 and the set time is 1000 ms.

$$1000 \div (4 \times 2.5) = 100(\text{count})$$

(3) Averaging processing by specifying a count

The time taken for the average value derived by count averaging to be stored in the buffer memory varies depending on the number of channels used.

$$(\text{Processing time}) = (\text{Set count}) \times (\text{Number of used channels}) \times 2.5(\text{ms/channel})$$

↑
Max. conversion speed

Example: When the number of channels used is 4 and the set count is 500.

$$500 \times 4 \times 2.5 = 5000(\text{ms})$$

2.3 I/O List with Respect to Programmable Controller CPU

The I/O signals of the 68AD with respect to a programmable controller CPU are as indicated below. Numbers for X and Y are determined by the slot occupied by the 68AD and the number of points of the other I/O units.

The I/O numbers indicated below are used when the 68AD unit is loaded into slot No. 0 of the main base unit.

- (1) Input signals with respect to programmable controller CPU, 32 points from X0 to 1F.

Input Signal	Description
X0	Watch dog timer error Turns on if a watch dog timer error occurs in the 68AD.
X1	A/D conversion ready (1) Turns on when A/D conversion is ready (not in test mode) after the power is turned on or the programmable controller CPU is reset. Turns off in test mode. (2) Used as an interlock when read or write is performed from the programmable controller CPU to the 68AD.
X2 to X1F	Not used

REMARK

A/D conversion ready indicates that a digital output value has been stored into the buffer memory after the A/D conversion of all eight channels has been completed.

- (2) Output signals with respect to programmable controller CPU, 32 points from Y0 to 1F.

Output Signal	Description
Y0 to Y1F	Not used

IMPORTANT

Outputs Y0 to 1F are reserved, they should not be used in the sequence program.

If the 68AD is used in a remote I/O rack, Y0E and Y0F may be reset in the user program. For details, refer to the A0J2 Data Link Unit User's Manual.

2.4 Buffer Memory

The 68AD is equipped with a buffer memory (which is not battery backed) for the communication of data with a programmable controller CPU. Explanation will be given for the assignment and data configuration of this buffer memory.

For the read and write operation procedures by the sequence program, refer to Chapter 6 (page 6-1).

2.4.1 Assignment of buffer memory

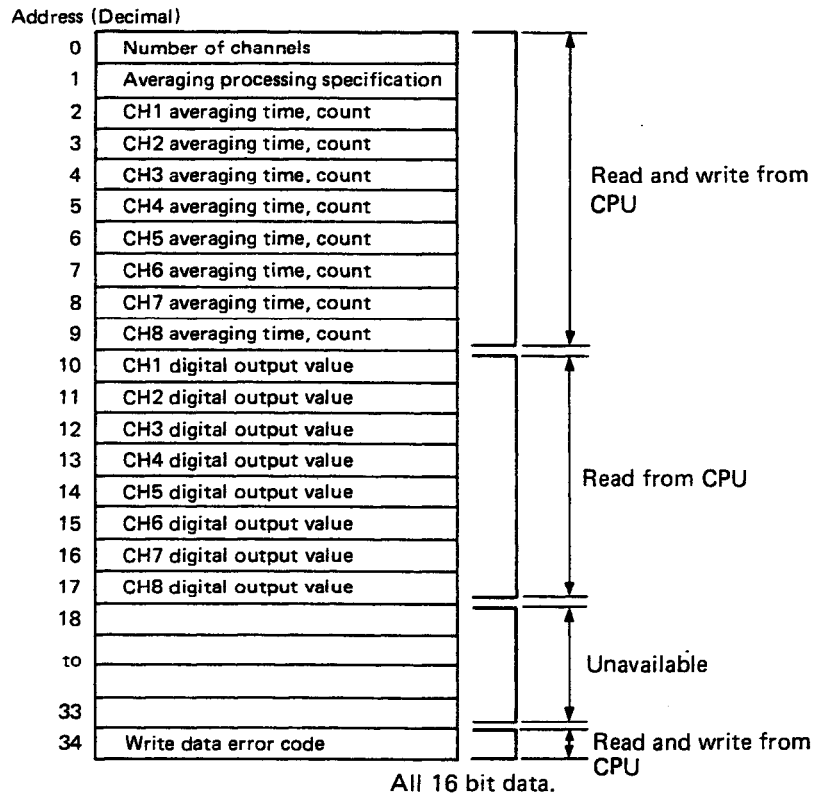

POINT

The addresses 10 to 17 of buffer memory are areas exclusively used for reading from a programmable controller CPU. Writing to these addresses will cause mis operation.

2.4.2 Contents and data configuration of buffer memory

This section describes the contents and data configuration of buffer memory for each item indicated in Section 2.4.1 (page 2-12).

(1) Number of channels (Address 0)

- a) At power-on, the number of channels is set to 8.
- b) In order to reduce sampling time, the number of channels can be changed by in the sequence program. (For details, refer to Section 6.2.2 on page 6-4)

Example:	CH1	Used	}	By setting the number of channels to 4, the sampling time is changed to 2.5ms x 4 = 10ms.
	CH2	Vacant		
	CH3	Used		
	CH4	Used		
	CH5	Vacant		
	CH6	Vacant		
	CH7	Vacant		
	CH8	Vacant		

POINTS

1. Although the number of channels at power-on is set inside the 68AD, it is not written to address 0 of the buffer memory.
2. When 0 is written for the number of channels, the 68AD regards the number of channels as 8 when performing A/D conversion processing.
3. When a number of channels other than 0 to 8 is written, setting error occurs and the buffer memory is rewritten. However, the 68AD performs A/D conversion processing for the number of channels set previously.

(2) Averaging processing specification (Address 1)

- a) When the power is turned on and the A/D conversion ready signal of A68AD is on, all channels are set to sampling processing.
- b) For selection of sampling processing or averaging processing use address 1 of the buffer memory.

B15	B14	B13	B12	B11	B10	B9	B8	B7	B6	B5	B4	B3	B2	B1	B0
CH8	CH7	CH6	CH5	CH4	CH3	CH2	CH1	CH8	CH7	CH6	CH5	CH4	CH3	CH2	CH1

Specification of channel for which averaging processing will be performed

- 1: Averaging processing
- 0: Sampling processing

Specification of time/count

- 1: Time averaging
- 0: Count averaging

POINT

When averaging processing is not specified, sampling processing is set without regard to the specification of time/count.

(3) Averaging time, averaging count (Addresses 2 to 9)

- a) At power-on, the averaging time and averaging count are set to 0.
- b) The setting ranges are as indicated below:

Averaging processing in terms of count: 1 to 4000 times
 Averaging processing in terms of time: 20 to 10000ms

POINT

If a value outside the above range has been written, setting error occurs and the buffer memory is rewritten. However, the 68AD performs A/D conversion processing at the averaging time or count previously set.

(4) Digital output value (Addresses 10 to 17)

The digital output value is expressed in 16-bit, signed binary within the range from -2048 to +2047.

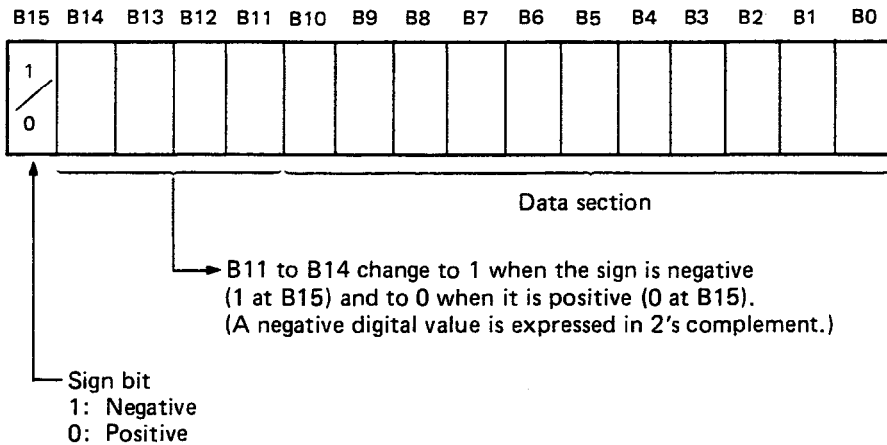

(5) Write data error code (Address 34)

- a) When data is read from the programmable controller CPU, the 68AD makes a data range check for the number of channels used once only. When one of the values is outside the range, the 68AD sets an error code in 16-bit binary. For details of error codes, refer to Section 8.1 (page 8-1).
- b) To reset an error code, write 0 from the programmable controller CPU.
- c) When several error codes have occurred, the data error code, which has been detected by the 68AD first, is stored. The other errors are not stored.
- d) If an error is reset without remedying the error, the data error code is set to 0 and the RUN LED of 68AD stops flickering (Section 3.2.1 on page 3-2).

3. HANDLING

This chapter describes the handling instructions, nomenclature, maintenance, and inspection of the 68AD.

3.1 Handling Instructions

- (1) Protect the 68AD and its terminal block from impact.
- (2) Do not touch or remove the printed circuit board from the case.
- (3) When wiring, ensure that no wire offcuts enter the unit and remove any that do enter.
- (4) Tighten terminal screws as specified below.

Screw	Tightening Torque Range (N-cm)
I/O terminal block terminal screw (M3 screw)	39 to 59
I/O terminal block mounting screw (M4 screw)	78 to 118

- (5) To load the unit onto the base, press the unit against the base so that the hook is securely locked. To unload the unit, push the catch on the top of the unit, and after the hook is disengaged from the base, pull the unit toward you.

3. HANDLING



3.2 Nomenclature

3.2.1 Nomenclature

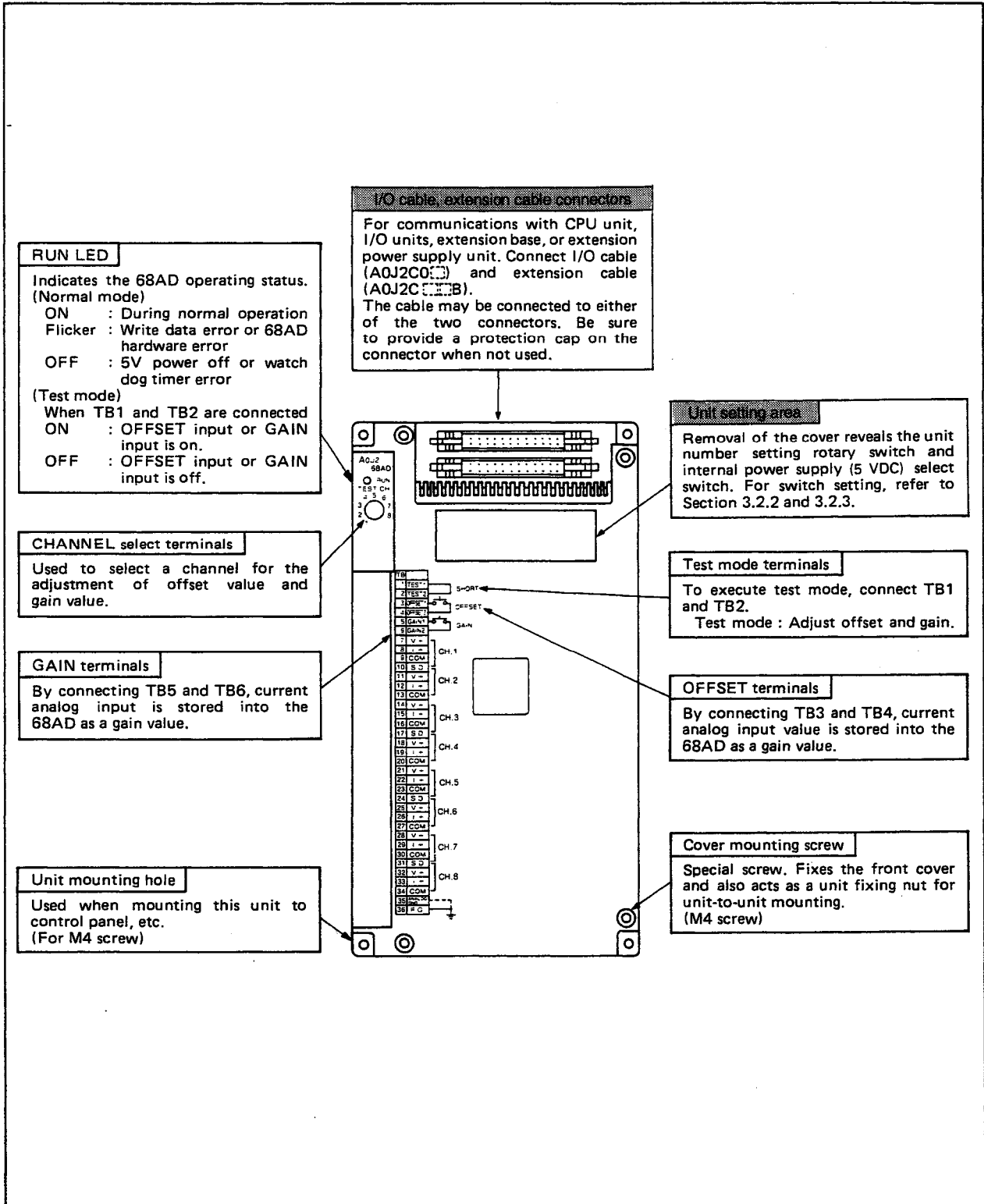

REMARK

It is necessary to set the areas marked [shaded] prior to test operation and adjustments.

3.2.2 Unit number setting

This section describes unit number setting.

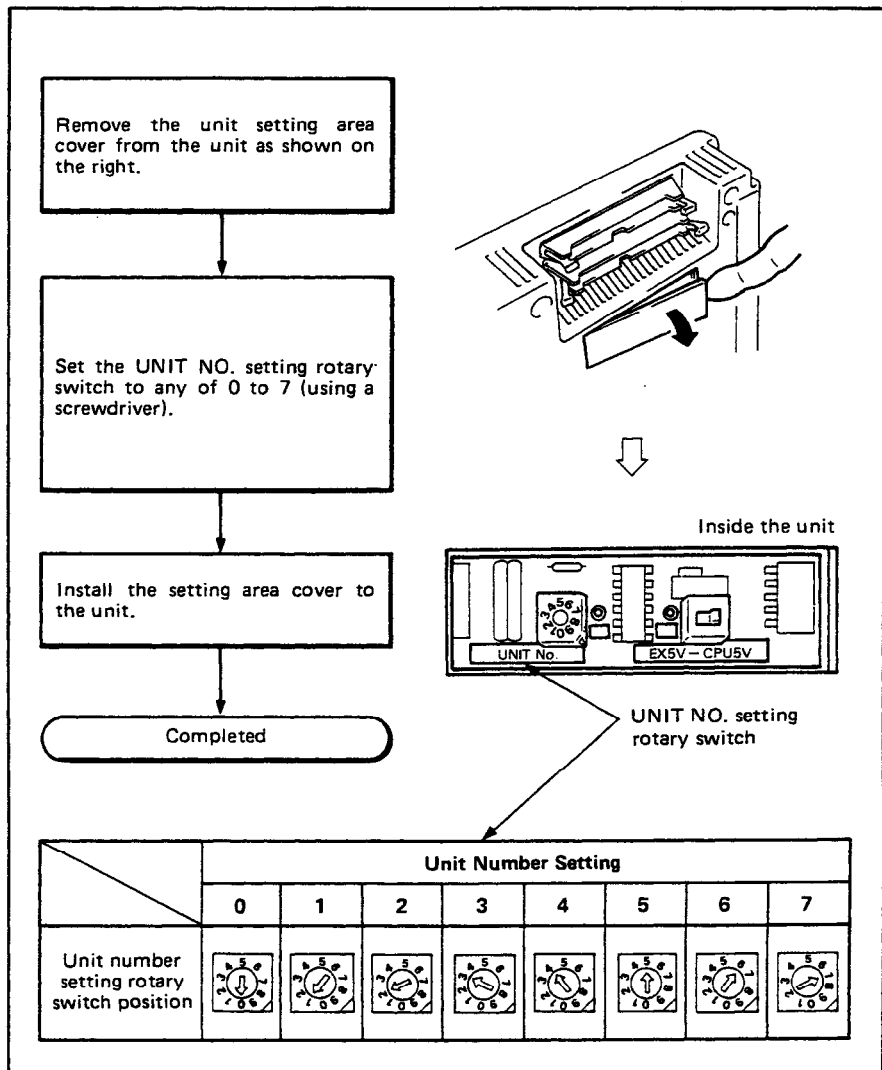

POINTS

- (1) Set the unit number setting rotary switch to any of 0 to 7 according to the unit stage number. Note if that the same unit number is set to two or more units, misinput and misoutput will occur.
- (2) The unit number setting determines X and Y addresses. For details, refer to Chapter 5.

3.2.3 Internal power supply (5 VDC) setting

Set the internal power supply (5 VDC) of the 68AD as explained below.

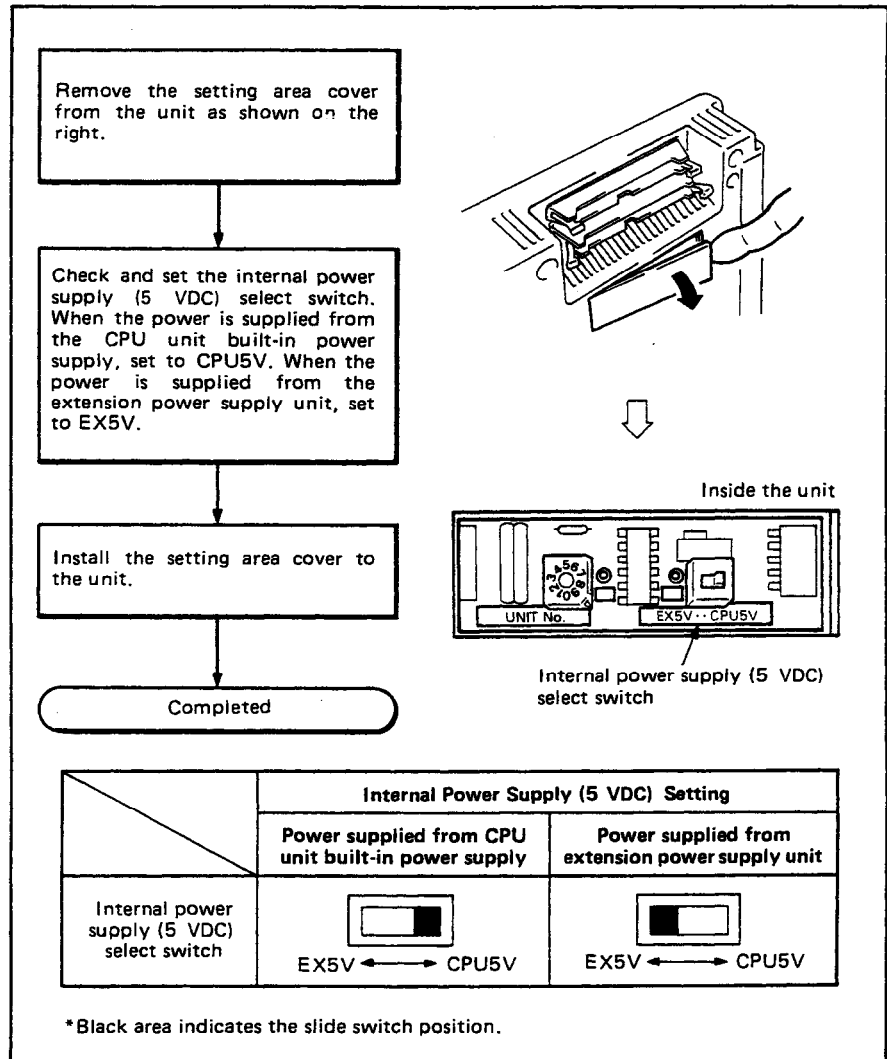

POINTS

- (1) If the select switch is set to EX5V when 5 VDC is supplied from the internal power supply of the CPU unit to the 68AD, the 68AD does not operate properly. Always check this before test operation.
- (2) To set the internal power supply in a system which uses the A0J2PW extension power supply unit, refer to Section 5.2 of the A0J2CPU User's Manual (CPU unit edition).

3.2.4 Internal power supply (5 VDC) checking

Check the internal power supply (5 VDC) of the 68AD as explained below using a circuit tester.

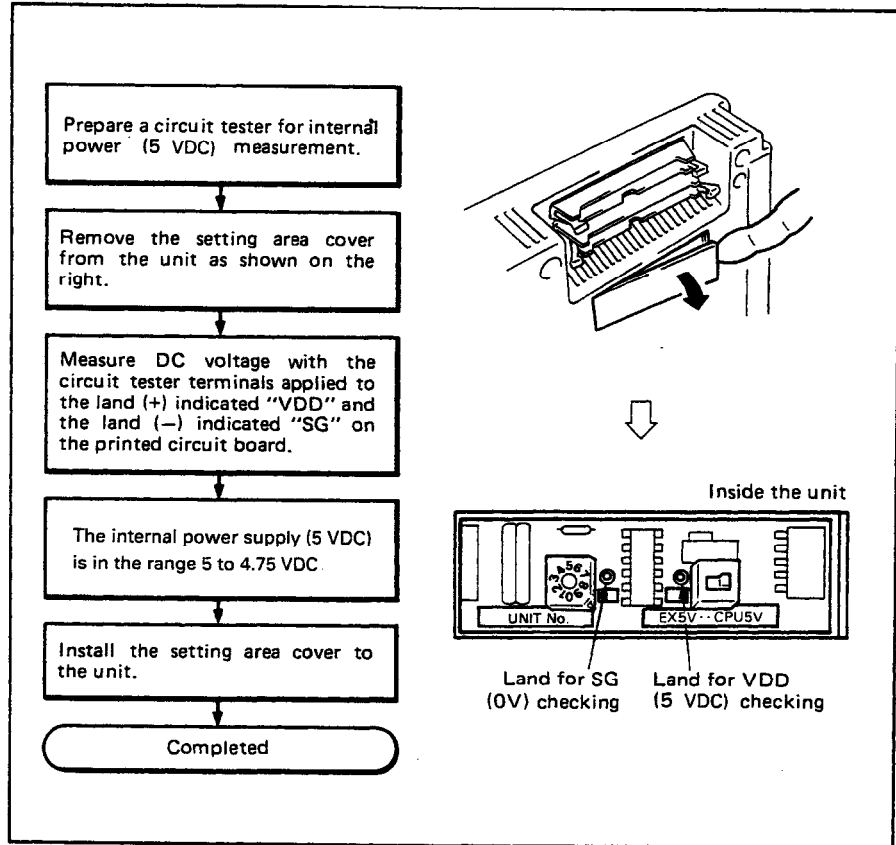

4. WIRING

4.1 Wiring Instructions

Protect external wiring against noise with the following precautions:

- (1) Separate AC and DC wiring.
- (2) Separate main circuit and/or high voltage wiring from control and signal wiring.
- (3) Where applicable, ground the shielding of all wires to a common ground point.

4.2 Unit Connection Example

(1) Voltage input

Signal source: 0 to $\pm 10V$

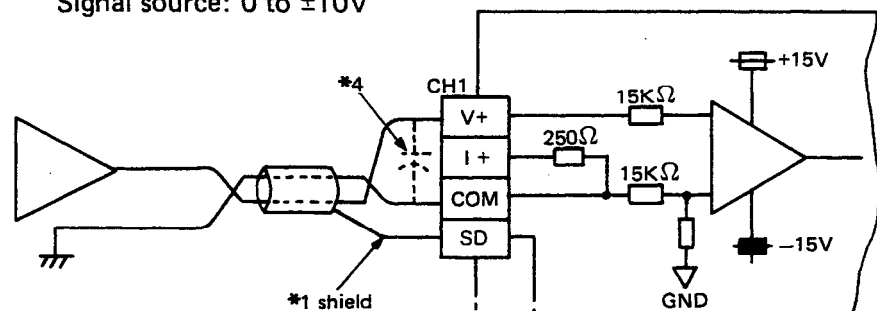

(2) Current input

Signal source: 0 to $\pm 20mA$

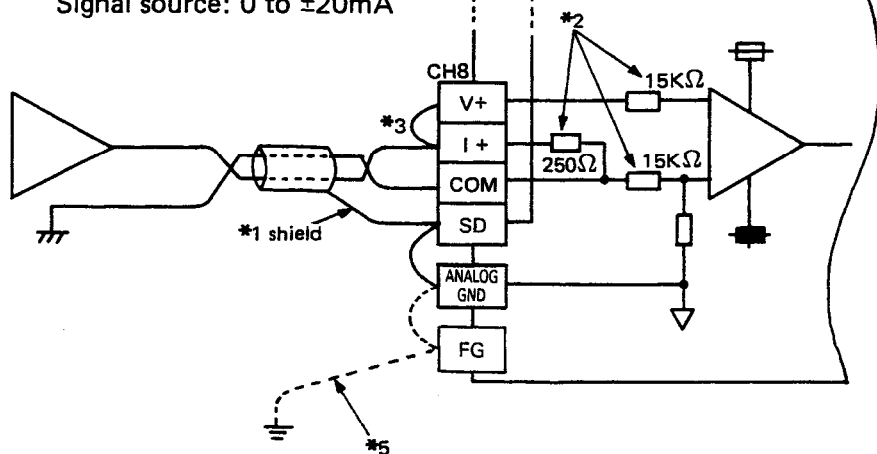

*1: For the cable, use a two-core twisted shielded wire.

*2: Indicates the input resistance of the 68AD.

*3: For current input, be sure to connect the terminals (V+) and (I+).

*4: If noise or ripple is generated at the external wiring, connect a capacitor of approximately 0.1 to 0.47 μF (25V or more voltage resistance parts.) between terminals V and COM.

*5: If there is excessive noise, ground the unit. In some cases, it is suggested to ground FG of the power supply unit at the same time.

POINT

The FG terminal of the 68AD and the FG terminal of the power supply unit are not connected together internally.

5. CONCEPT OF THE 68AD I/O NUMBERS IN A0J2 SYSTEM

This chapter explains the concept and precautions for the 68AD I/O numbers in the A0J2 system.

5.1 I/O Number Assignment and Concept

The I/O number assignment is one of the requirements for constructing a system. Wrong assignment will result in failure. Assign the I/O numbers as described below.

(1) X and Y represent input and outputs, respectively. I/O numbers are addressed in hexadecimal. (0 to F)

(2) I/O numbers are determined by the unit number set in the 68AD. One unit occupies 64 points.

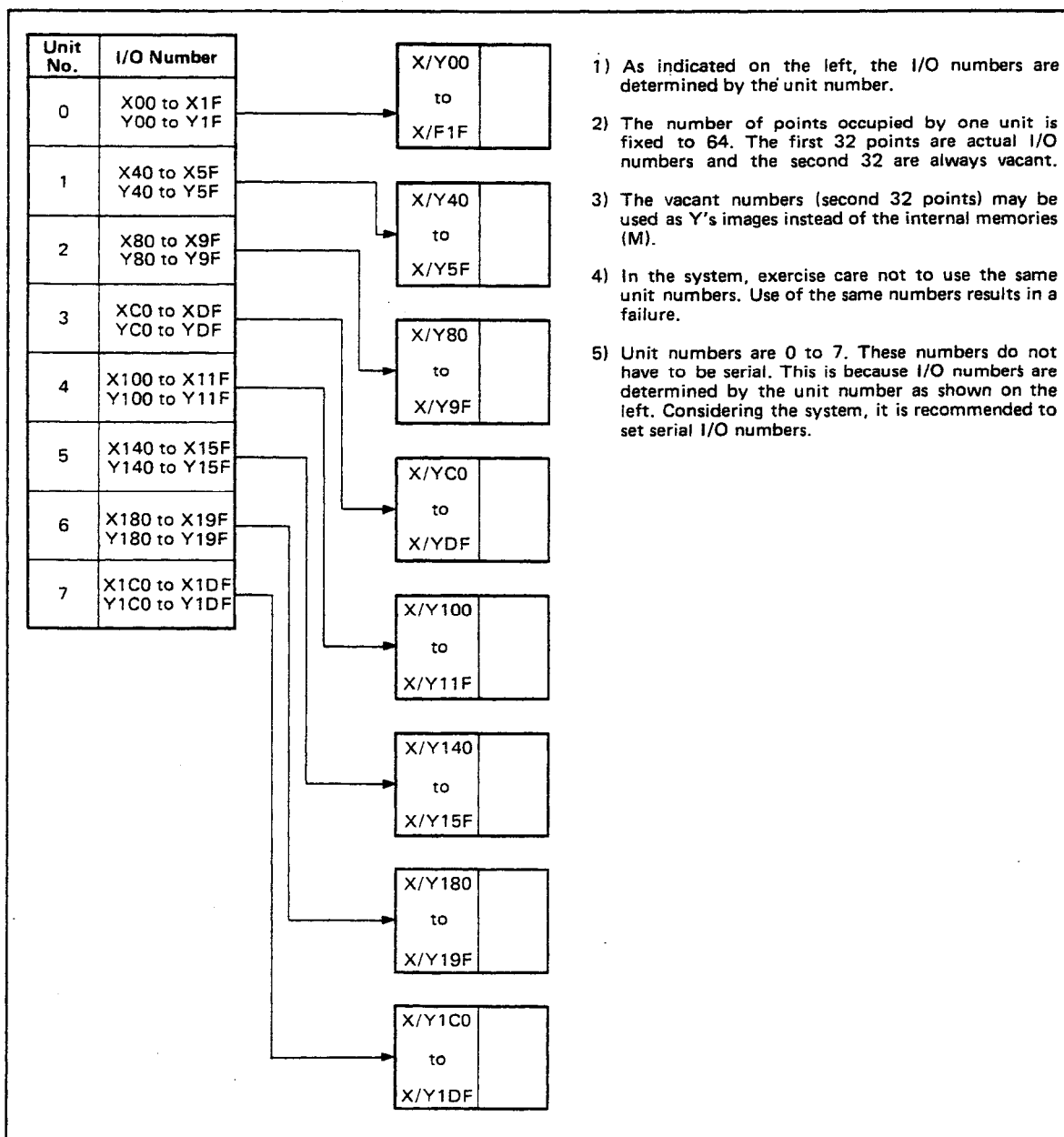

5.2 Concept of Parallel I/O Assignment for Use with Remote Station

For the I/O number assignment in a remote station using the A0J2P25/R25, serial and parallel I/O assignments are available. For details, refer to the A0J2 Data Link Unit User's Manual.

This section explains the precaution for parallel I/O assignment.

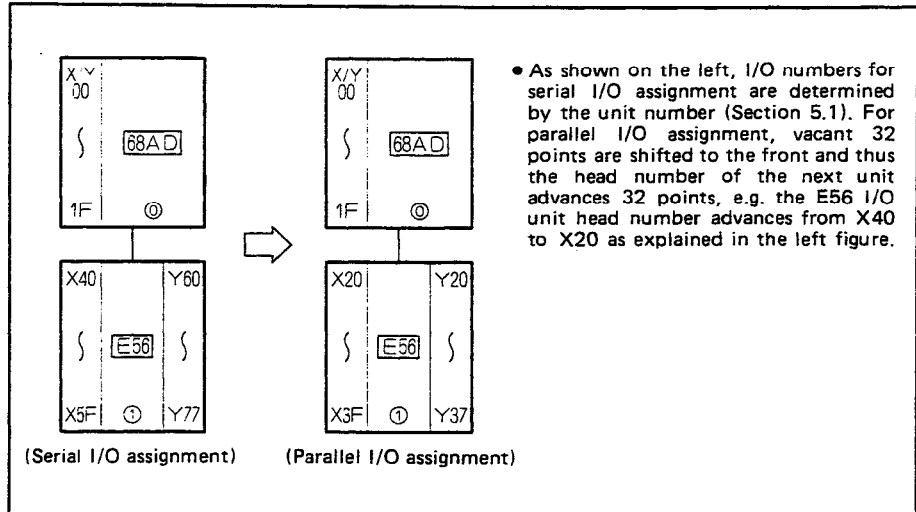

6. PROGRAMMING

6.1 Initial Setting

Execute initial setting from the PC CPU to the 68AD in the sequence indicated in Fig. 6.1. If the order of the averaging time or averaging count setting and averaging processing specification is reversed, a write data error may occur. You are therefore recommended to perform initial setting by using a single write instruction for writing to the 68AD.

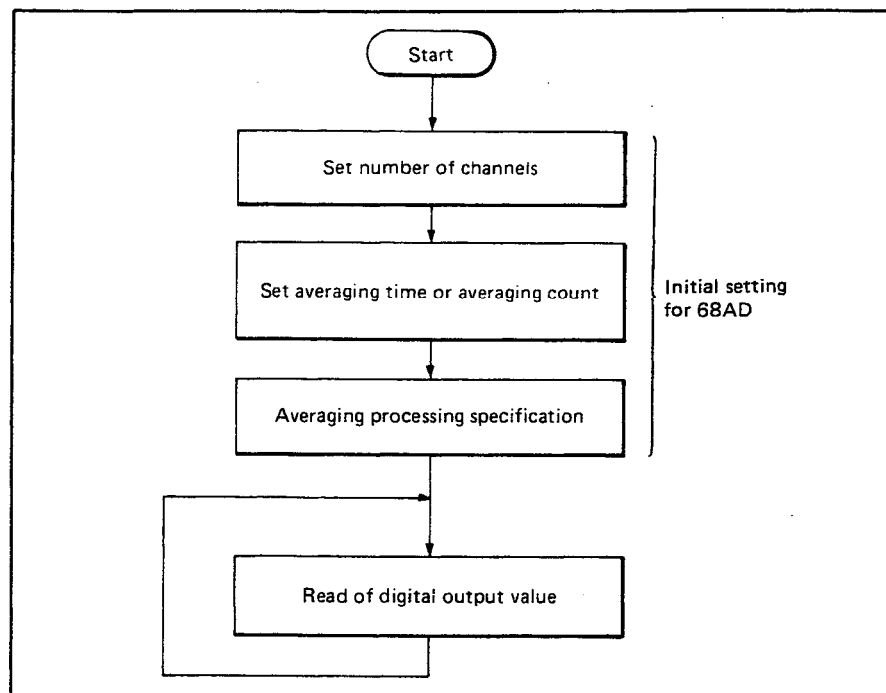

Fig. 6.1 Initial Setting Procedure

Unless otherwise stated, the I/O numbers indicated below are those when the station number setting is 0. For details on I/O numbers with respect to the PC CPU and buffer memory allocations, see Section 2.4.1.

6.2 Programs

6.2.1 Basic programs for read and write

(1) Read from 68AD : FROM, DFRO instructions

*1 FROM instruction execution condition

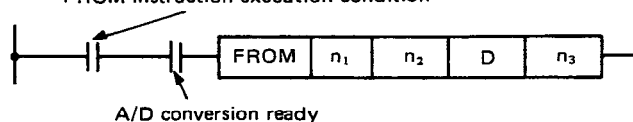

Symbol	Description	Usable Device Number
n ₁	Upper 2 digits of the Hexadecimal 3 digit head I/O number to A68AD (e.g. 4 when the I/O number is X, Y040)	K, H
n ₂	Head address of buffer memory which stores data	K, H
D	Head number of device which will stored read data	T, C, D, W
n ₃	Number of words of data to be read	K, H

Example: To read the 1 word data from address 10 of the buffer memory to D0, with the 68AD assigned to I/O X00 to 01F and Y00 to 1F

*1 FROM instruction execution condition

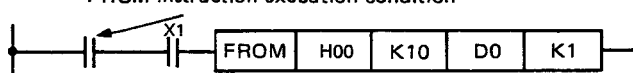

(2) Write to 68AD : TO, DTO instructions

*1 TO instruction execution condition

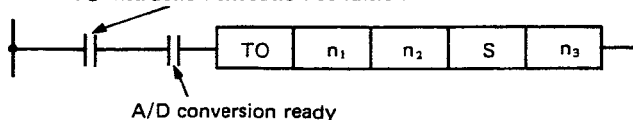

Symbol	Description	Usable Device Number
n ₁	Upper 2 digits of the Hexadecimal 3 digit head I/O number to A68AD (e.g. 4 when the I/O number is X, Y040)	K, H
n ₂	Head address of buffer memory which will store data	K, H
D	Head device number or constant where data to be written is stored.	T, C, D, W
n ₃	Number of words of data to be written	K, H

Example: To write D0 to address 0 of the buffer memory, with the 68AD assigned to I/O X00 to 01F and Y00 to 1F

*1 TO instruction execution condition

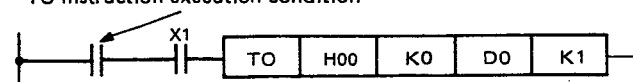

REMARK

Convert the instructions marked *1 into pulse.

6.2.2 Setting the number of channels

- (1) Set the number of channels 1 to 8.
- (2) Even if there is a vacant channel, the number of channels must begin with channel 1. Set the number of the last channel used.
- (3) Program example

To set the number of channels 3

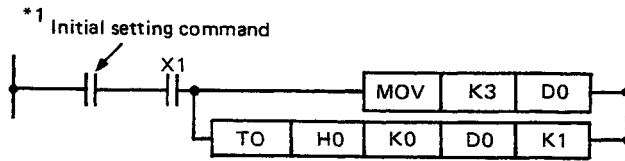

6.2.3 Setting of averaging time or averaging count

- (1) Set the averaging time or averaging count to each channel for which averaging processing will be performed.
- (2) Be sure to set the averaging time or averaging count before specifying the averaging processing.
- (3) Set value

Time: 20 to 10000ms (Set the time in units of 10ms.)

Count: 1 to 4000 times

- (4) Program example

To set the averaging time of 1000ms to channel 1 and the averaging count of 10 times to channel 3

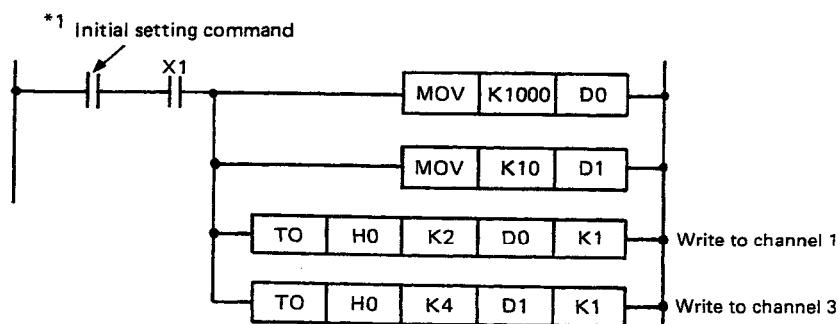

6.2.4 Averaging processing specification

- (1) Specify the channels for which averaging processing will be performed, and also specify whether the processing method is count averaging or time averaging.
- (2) Be sure to specify the averaging processing method after setting the averaging time and/or averaging count.

(3) Program example

To specify time averaging processing at channel 1, sampling processing at channel 2, and count averaging processing at channel 3.

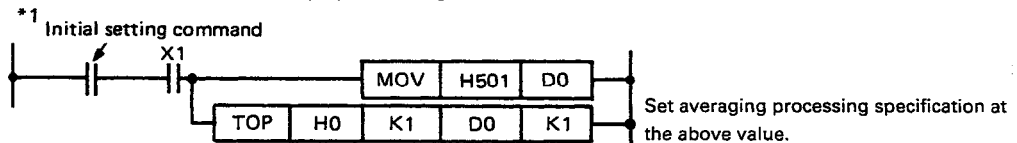
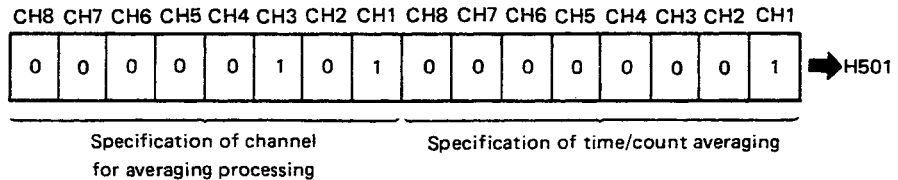

REMARK

Convert the instructions marked *1 into pulse.

6.2.5 Read of digital output value

(1) The digital output value is read in 16-bit, signed binary.

(2) Program example

To read the digital output values of channels 1 to 3 to the D5 to 7.

*1 Digital output value read command

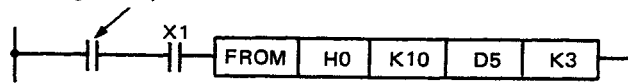

6.2.6 Read and reset of write data error code

(1) Any error code is set at address 34 of the buffer memory in binary. For details, refer to Section 8.1 (page 8-1).

(2) Only the first error code to occur, is stored. For details, refer to Section 2.4.2 (page 2-13).

(3) Reset the error code from the programmable controller CPU.

(4) Program example

a) To read the error code to D3 and output it to Y100 to 107 in BCD.

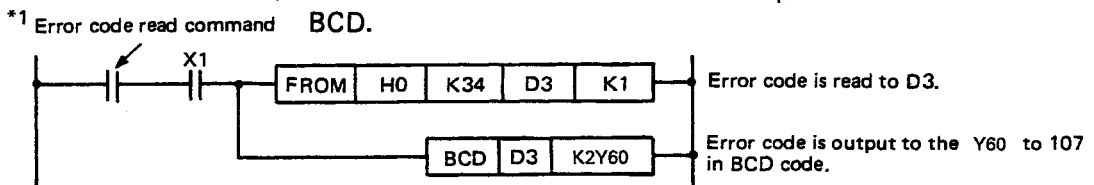

b) To reset the error code

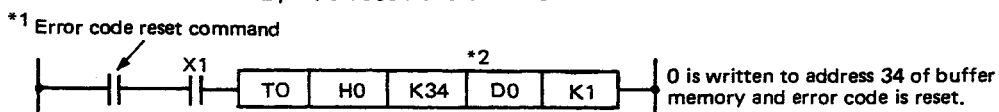

REMARKS

Convert the instructions marked *1 into pulse.

*2: The value in D0 should always be 0.

6.2.7 Application circuit examples

(1) Checking the magnitude of the analog signal

Program which turns on Y60 when the digital output value of channel 1 is 700 or more, turns on Y61 when it is between 600 and 700, and turns on Y62 when the value is negative.

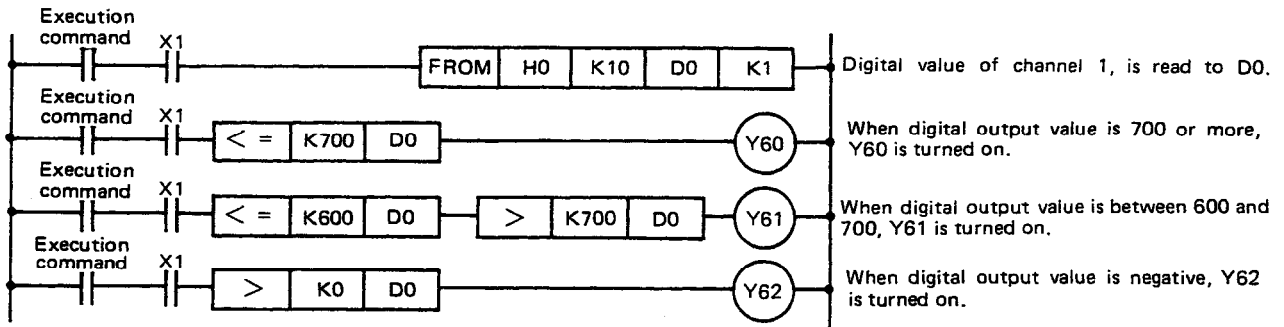

(2) Digital display of analog signal

Program which outputs the digital output value of channel 1 to Y60 to 6F in BCD and turns on Y70 when that value is negative.

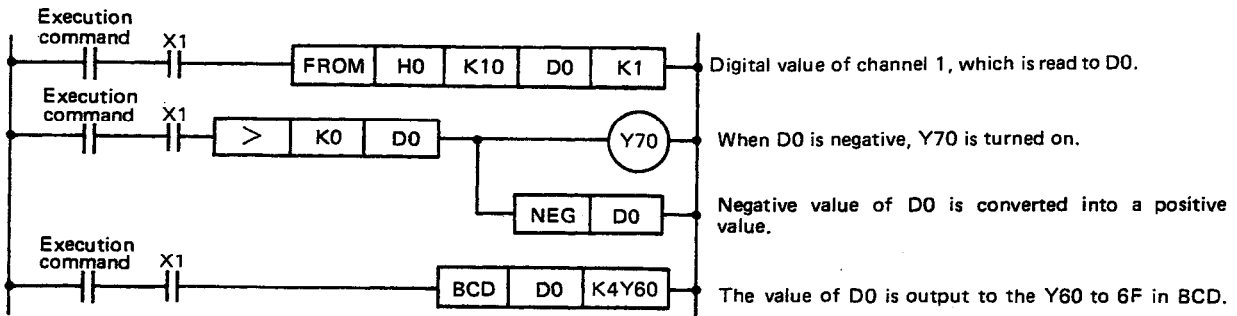

(3) Circuit which changes a gain to 4, 2, 1/2, and 1/4 times by program

The digital output values are changed to the following gains; (all digital value must be > 0)

- Channel 1: 4 times
- Channel 2: 2 times
- Channel 3: 1/2 times
- Channel 4: 1/4 times

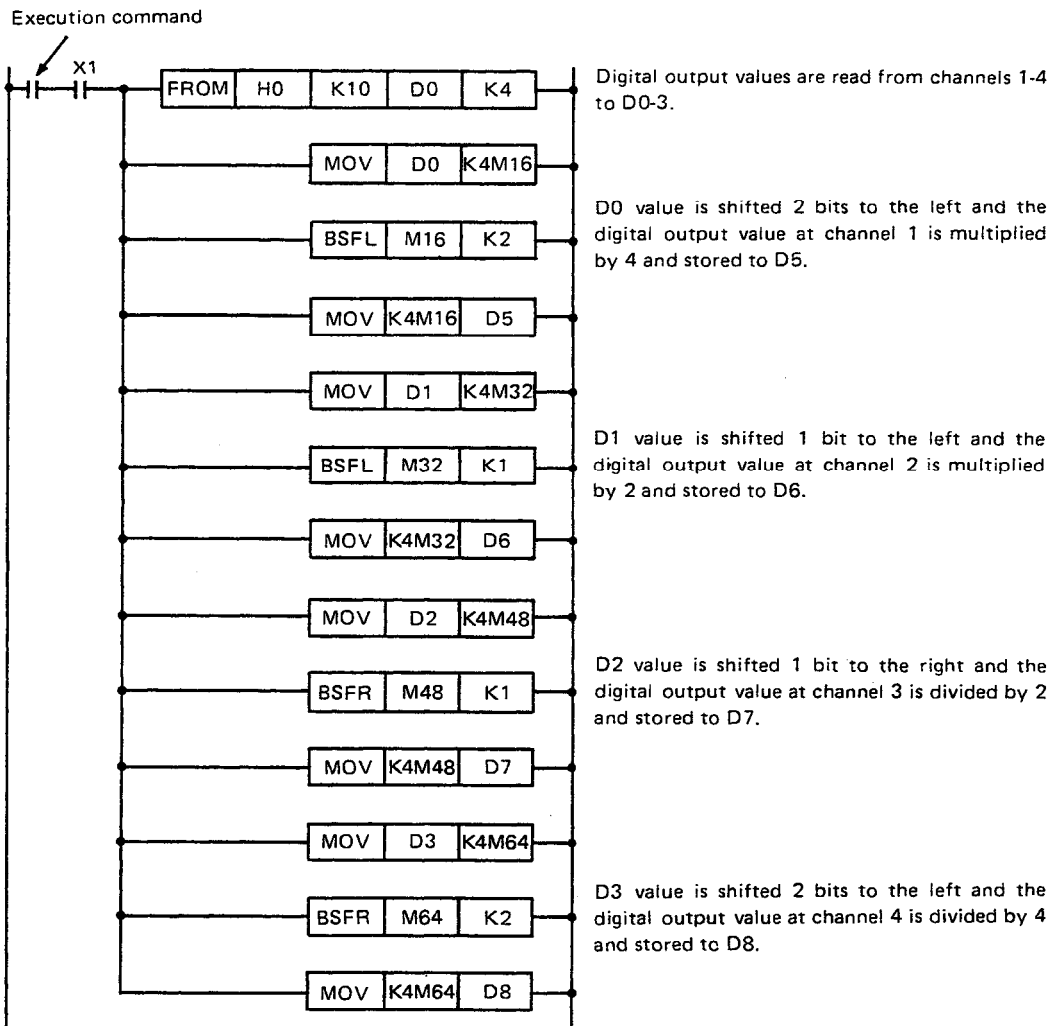

7. TEST OPERATION AND CALIBRATION

This chapter describes offset/gain setting.
See also the A CPU User's Manual.

7.1 Offset/Gain Setting

Change the output characteristics as follows. The unit is factory-set to an offset value of 0V and a gain value of 5V.

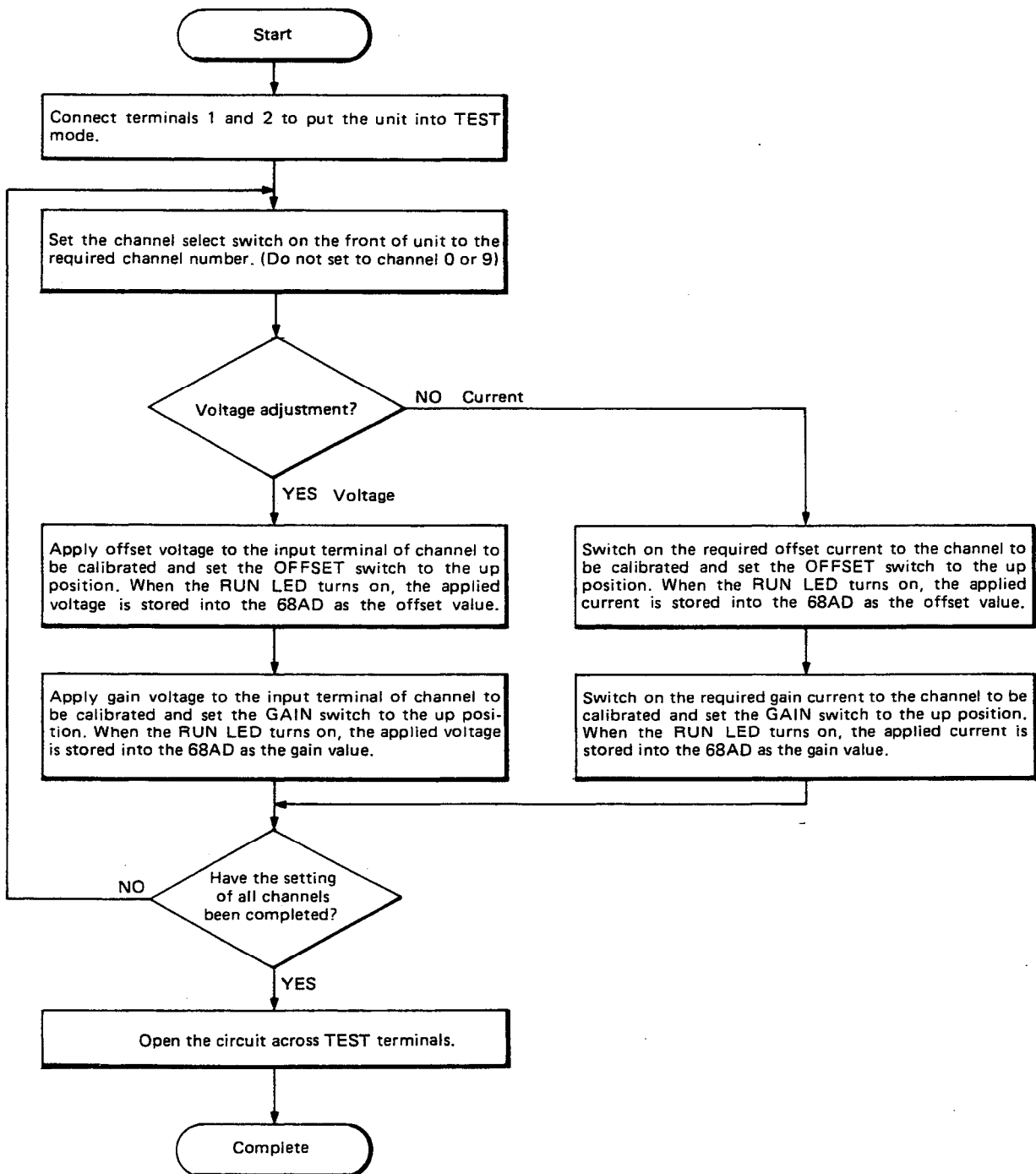

POINTS

1. The offset value and gain value are stored in the 68AD and are not erased if the power is turned off.
2. Perform the offset/gain setting with the CPU in stop mode. When the unit is set to test mode, A/D conversion is stopped on all channels. Therefore, use the A/D conversion ready signal as an interlock.
3. Perform the offset/gain setting within the range -10 to 0 to $+10$ VDC or -20 to 0 to $+20$ m ADC. If set outside this range, the maximum resolution and overall accuracy may not be within the ranges specified.

7.2 Checks before Starting

Number	Checking Point	Description	Check
1	Loading of unit	Is the I/O assignment correct?	
2	Offset/gain setting	Has offset/gain been set for all channels used?	
		Are set values correct?	
		Has the unit been returned to normal mode by opening the circuit across TEST terminals?	
3	Connection to 68AD	Are terminal block connections correct?	
		Are terminal screws of terminal block tightened securely?	
		Is the wire size correct?	

Table 7.1 Points for Checking

8. TROUBLESHOOTING

This chapter describes errors, which may occur during the use of the 68AD, and troubleshooting procedures for such errors.

8.1 Write Data Error Code List

The following three errors may occur during the write operation of the number of channels, averaging processing specification, averaging time, and averaging count. The numeric value of the error code enclosed in [] indicates the channel number for which the error has occurred.

Description	Error Code
A value other than 0 to 8 has been set as the number of channels.	01
A value other than 20 to 10000ms has been set as an averaging time set value.	[] 0 to 4
A value other than 1 to 4000 times has been set as an averaging count set value.	[] 5 to 8

Table 8.1 Types of Write Data Error Codes

POINTS

- [] 0 to 4 and [] 5 to 8 of write data error code are used only to make differentiation between averaging time and averaging count, respectively. The individual numerals do not have any significance.
- When an error has occurred, check the write data error code, reset the error code, and then write the corrected data. (Refer to Section 2.4.2 on page 2-13.)

Example:

(1) Error code 32 has occurred

Since the averaging time of channel 3 is wrong, change the value to within the range 20 to 10000ms.

(2) Error code 88 has occurred

Since the averaging count of channel 8 is wrong, change the value to within the range 1 to 4000 times.

8.2 Troubleshooting

This section describes simple troubleshooting procedures for use of the 68AD. For problems relating to the CPU unit, refer to the A0J2CPU Programming Manual.

8.2.1 Troubleshooting flow chart

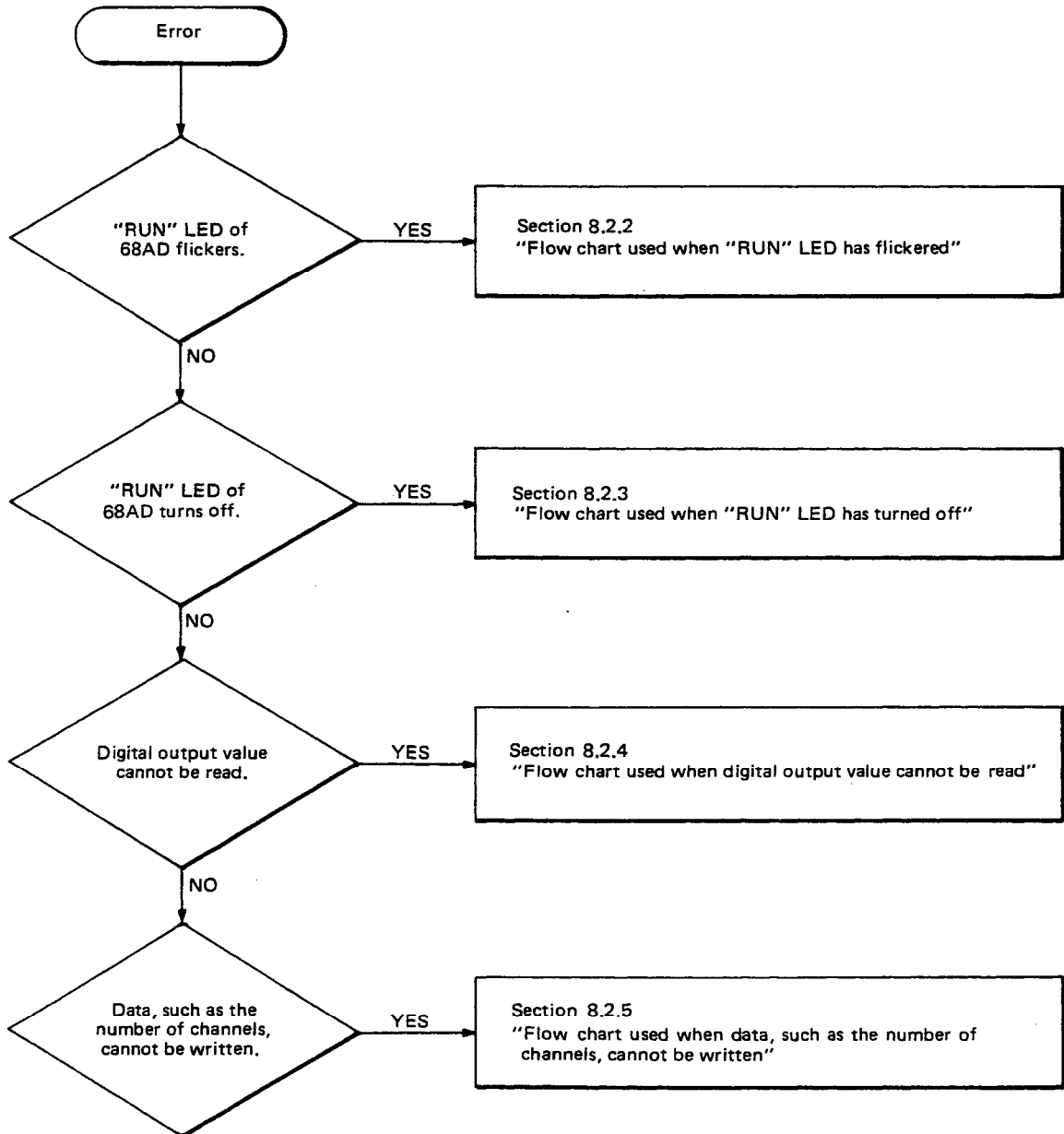

8.2.2 Flow chart used when "RUN" LED has flickered

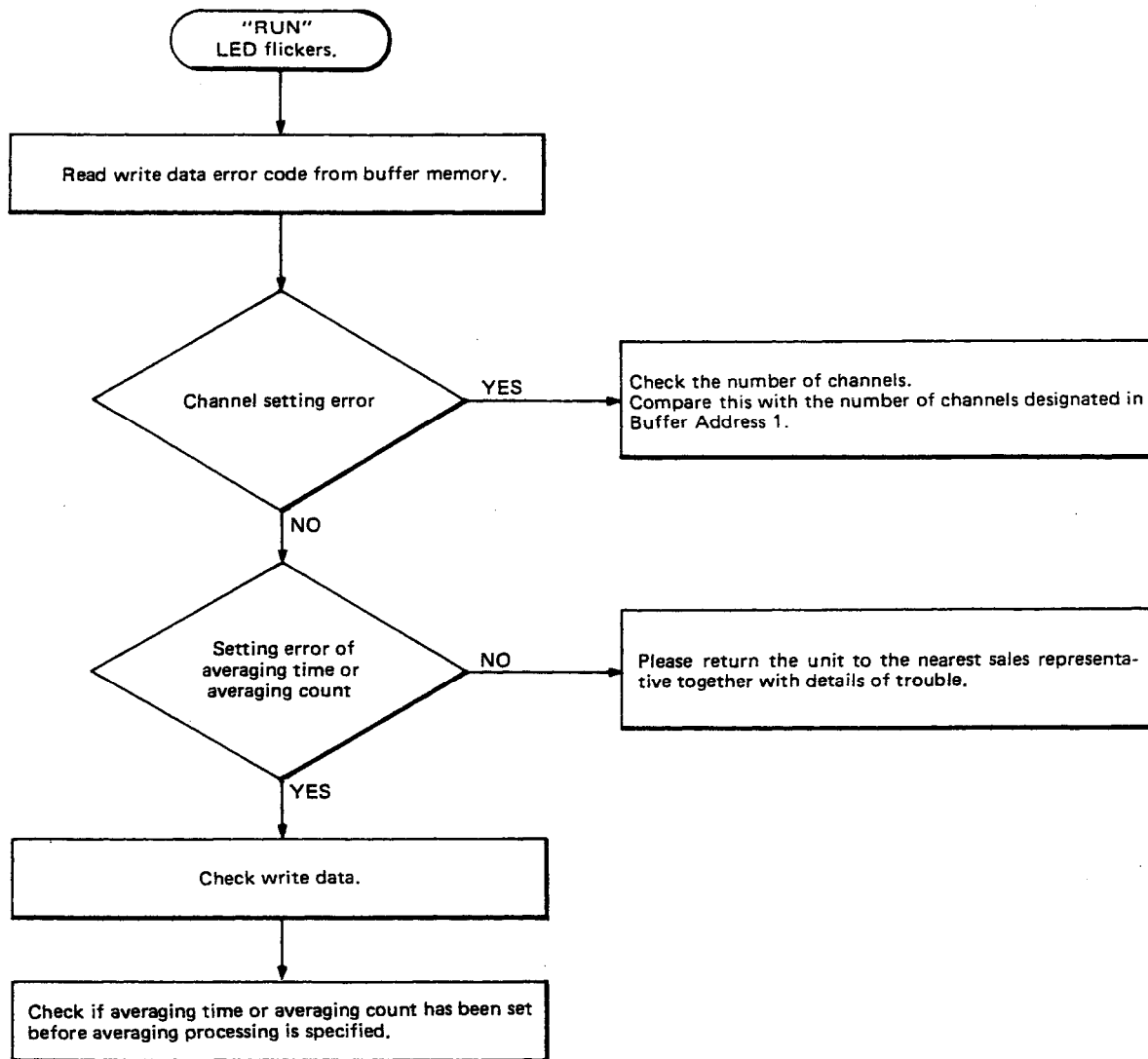

8.2.3 Flow chart used when "RUN" LED has turned off

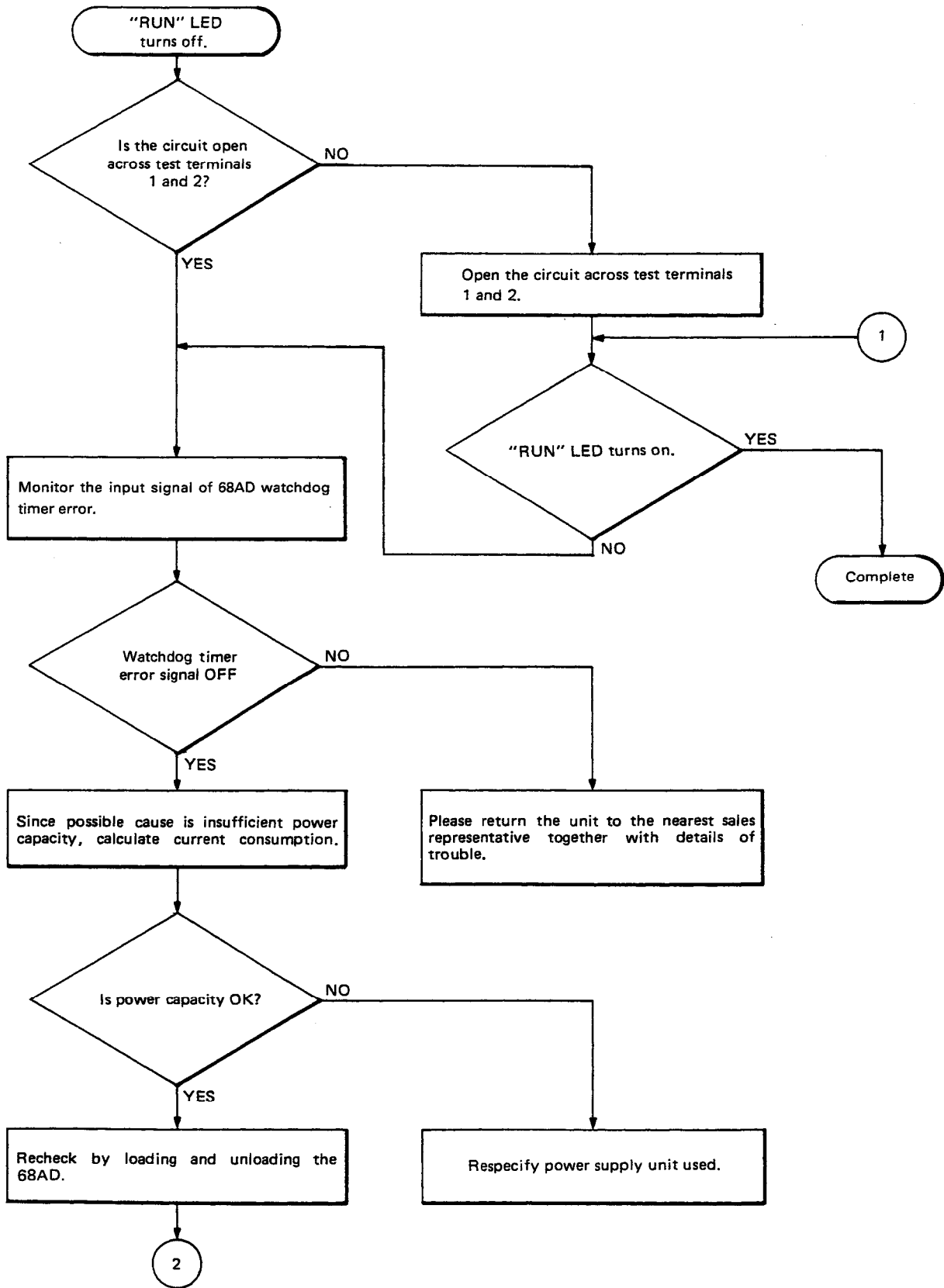

8.2.4 Flow chart used when digital output value cannot be read

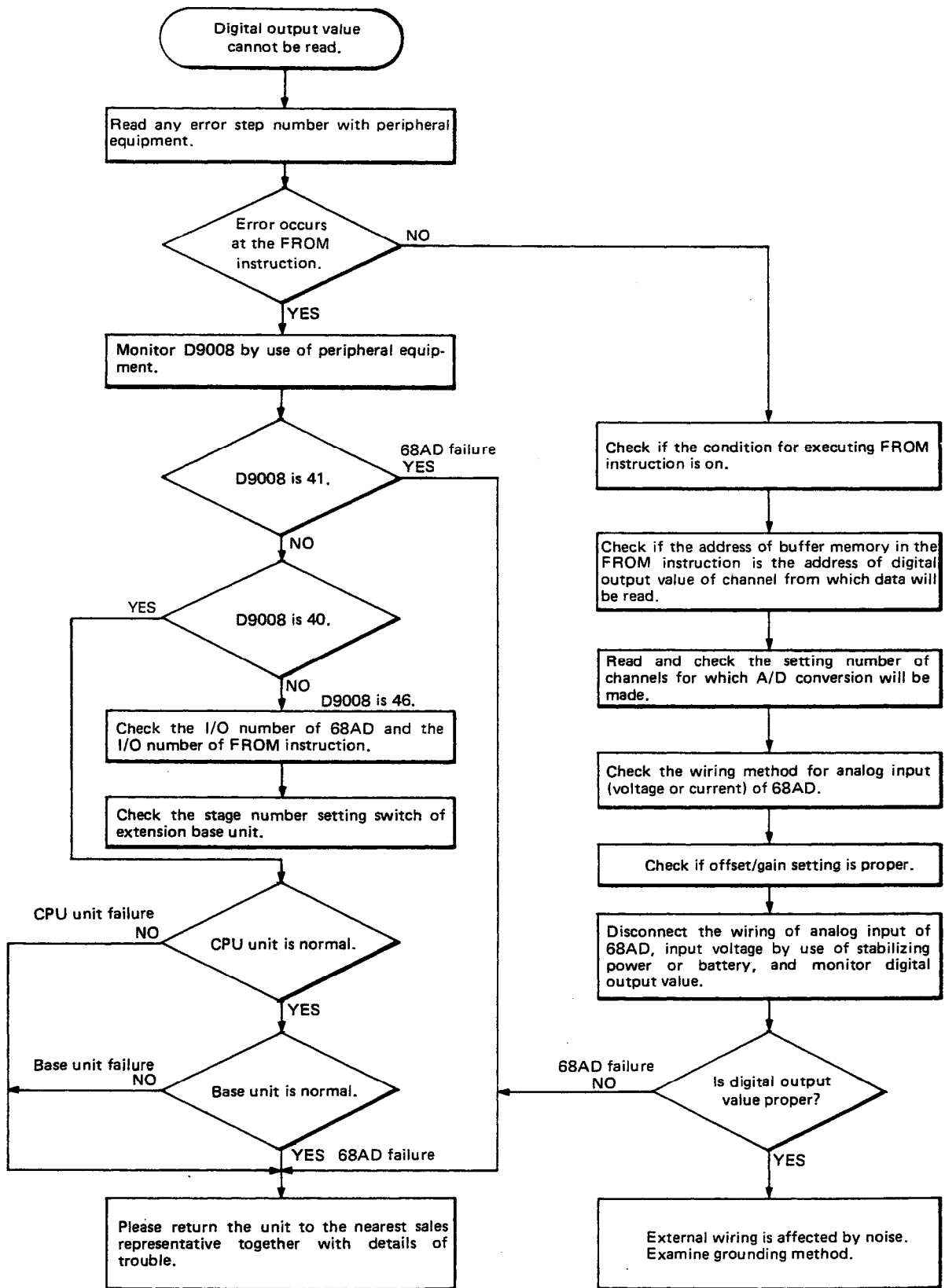

8.2.5 Flow chart used when data, such as the number of channels, cannot be written

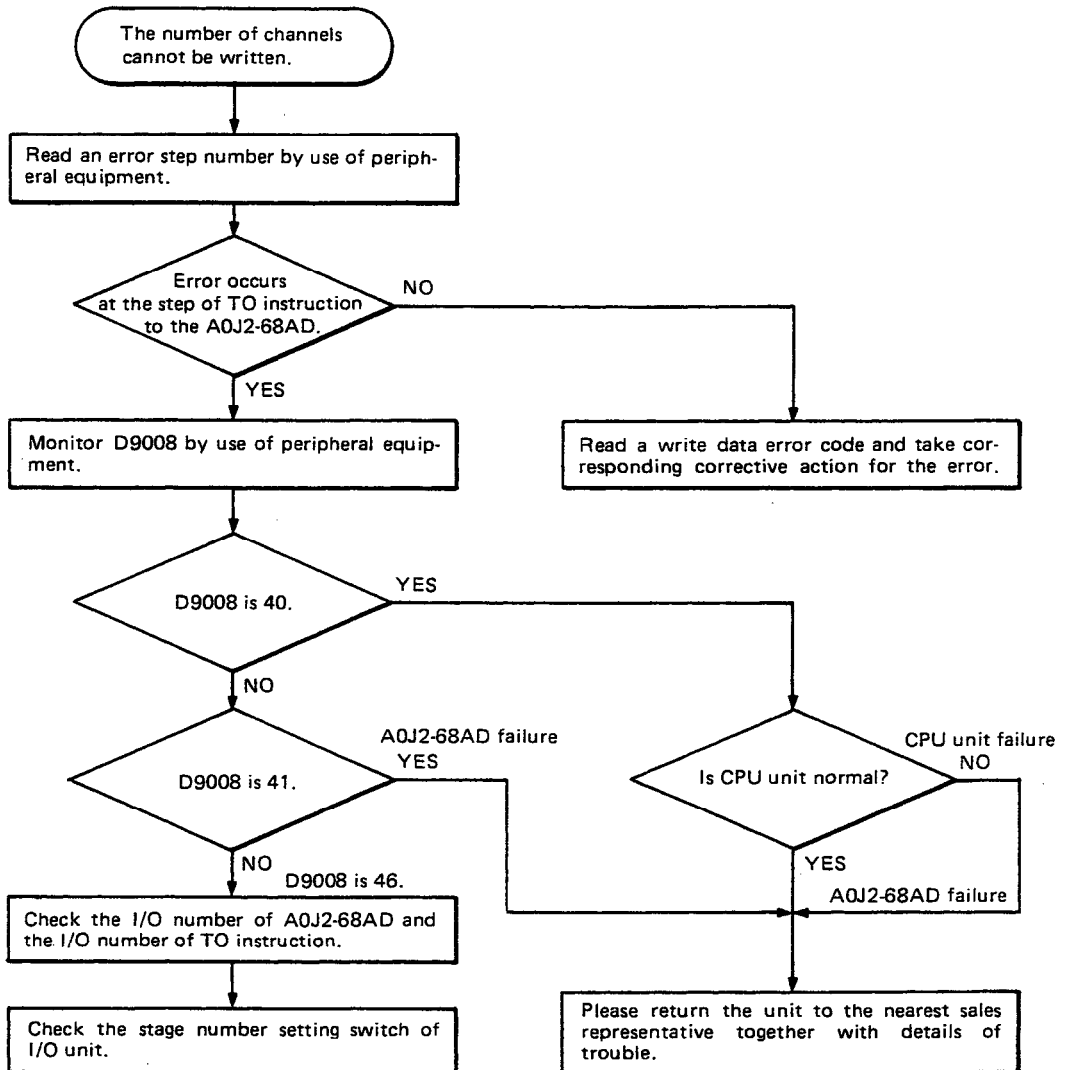

REMARK

The following contents are written into D9008 when an error has occurred during execution of the FROM or TO instruction to the 68AD.

Content (BIN value) of Special Register D9008	CPU Status	Error and Cause
40	Stop	FROM and TO instructions cannot be executed. Hardware failure of 68AD (special function unit), CPU unit, or base unit.
41	Stop	When the FROM or TO instruction has been executed, access has been made to the special function unit but no answer is returned. The accessed 68AD (special function unit) has failed.
46	Stop	Access has been made (FROM or TO instruction has been executed) to a slot where the 68AD (special function unit) is not loaded. The content of FROM or TO instruction is incorrect or the stage number setting of extension base unit is incorrect.

APPENDIX

APPENDIX 1 EXTERNAL DIMENSIONS

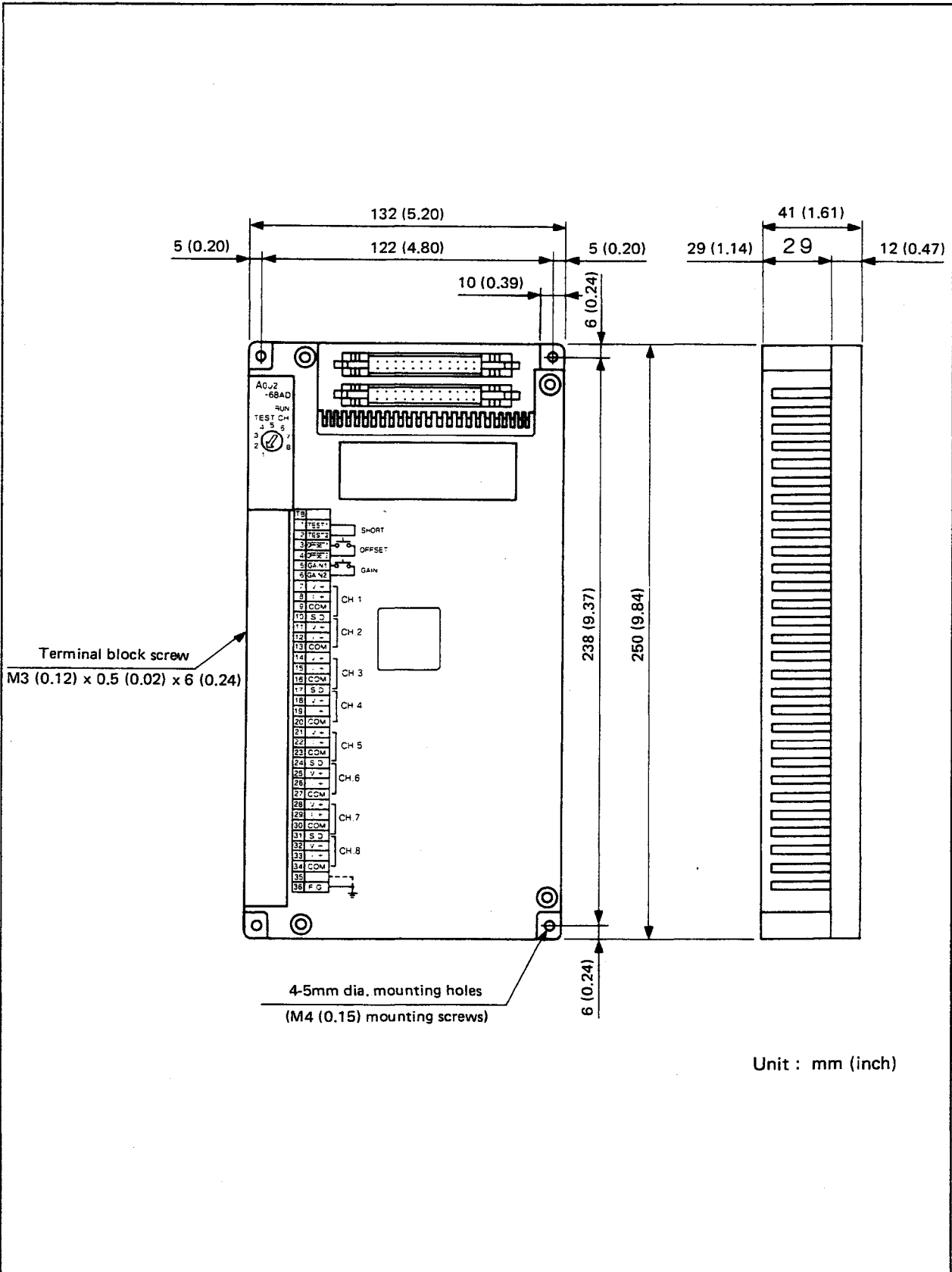

Unit : mm (inch)

WARRANTY

Please confirm the following product warranty details before starting use.

1. Gratis Warranty Term and Gratis Warranty Range

If any faults or defects (hereinafter "failure") found to be the responsibility of Mitsubishi occurs during use of the product within the gratis warranty term, the product shall be repaired at no cost via the dealer or Mitsubishi Service Company. Note that if repairs are required at a site overseas, on a detached island or remote place, expenses to dispatch an engineer shall be charged for.

[Gratis Warranty Term]

The gratis warranty term of the product shall be for one year after the date of purchase or delivery to a designated place.

Note that after manufacture and shipment from Mitsubishi, the maximum distribution period shall be six (6) months, and the longest gratis warranty term after manufacturing shall be eighteen (18) months. The gratis warranty term of repair parts shall not exceed the gratis warranty term before repairs.

[Gratis Warranty Range]

- (1) The range shall be limited to normal use within the usage state, usage methods and usage environment, etc., which follow the conditions and precautions, etc., given in the instruction manual, user's manual and caution labels on the product.
- (2) Even within the gratis warranty term, repairs shall be charged for in the following cases.
 1. Failure occurring from inappropriate storage or handling, carelessness or negligence by the user. Failure caused by the user's hardware or software design.
 2. Failure caused by unapproved modifications, etc., to the product by the user.
 3. When the Mitsubishi product is assembled into a user's device, failure that could have been avoided if functions or structures, judged as necessary in the legal safety measures the user's device is subject to or as necessary by industry standards, had been provided.
 4. Failure that could have been avoided if consumable parts (battery, backlight, fuse, etc.) designated in the instruction manual had been correctly serviced or replaced.
 5. Failure caused by external irresistible forces such as fires or abnormal voltages, and failure caused by force majeure such as earthquakes, lightning, wind and water damage.
 6. Failure caused by reasons unpredictable by scientific technology standards at time of shipment from Mitsubishi.
 7. Any other failure found to not be the responsibility of Mitsubishi or the user.

2. Onerous repair term after discontinuation of production

- (1) Mitsubishi shall accept onerous product repairs for seven (7) years after production of the product is discontinued. Discontinuation of production shall be notified with Mitsubishi Technical Bulletins, etc.
- (2) Product supply (including repair parts) is not possible after production is discontinued.

3. Overseas service

Overseas, repairs shall be accepted by Mitsubishi's local overseas FA Center. Note that the repair conditions at each FA Center may differ.

4. Exclusion of chance loss and secondary loss from warranty liability

Regardless of the gratis warranty term, Mitsubishi shall not be liable for compensation to damages caused by any cause found not to be the responsibility of Mitsubishi, chance losses, lost profits incurred to the user by failures in Mitsubishi products, damages and secondary damages caused from special reasons regardless of Mitsubishi's expectations, compensation for accidents, and compensation for damages to products other than Mitsubishi products and other duties.

5. Changes in product specifications

The specifications given in the catalogs, manuals or technical documents are subject to change without prior notice.

6. Product application

- (1) In using the Mitsubishi MELSEC programmable logic controller, the usage conditions shall be that the application will not lead to a major accident even if any problem or fault should occur in the programmable logic controller device, and that backup and fail-safe functions are systematically provided outside of the device for any problem or fault.
- (2) The Mitsubishi general-purpose programmable logic controller has been designed and manufactured for applications in general industries, etc. Thus, applications in which the public could be affected such as in nuclear power plants and other power plants operated by respective power companies, and applications in which a special quality assurance system is required, such as for each Japan Railways company or the Department of Defense shall be excluded from the programmable logic controller applications.

Note that even with these applications, if the user approves that the application is to be limited and a special quality is not required, application shall be possible.

When considering use in aircraft, medical applications, railways, incineration and fuel devices, manned transport devices, equipment for recreation and amusement, and safety devices, in which human life or assets could be greatly affected and for which a particularly high reliability is required in terms of safety and control system, please consult with Mitsubishi and discuss the required specifications.

A/D converter unit for A0J2 type A0J2-68AD

User's Manual

MODEL	A0J2-68AD-USERS-E
MODEL CODE	13J614
IB(NA)-66098-F(0307)MEE	

 **MITSUBISHI ELECTRIC CORPORATION**

HEAD OFFICE : 1-8-12, OFFICE TOWER Z 14F HARUMI CHUO-KU 104-6212, JAPAN
NAGOYA WORKS : 1-14, YADA-MINAMI 5-CHOME, HIGASHI-KU, NAGOYA, JAPAN

When exported from Japan, this manual does not require application to the Ministry of Economy, Trade and Industry for service transaction permission.

Specifications subject to change without notice.